

Wire Rope End Terminations





G-450

Forged Wire Rope Clips



G-429

What It Takes To Be "Crosby Or Equal"

FORGED FOR CRITICAL APPLICATIONS	COMPETITION	CROSBY
<p>The proper performance of forged clips depends on proper manufacturing practices that include good forging techniques and accurate machining. Forged clips provide a greater rope bearing surface and more consistent strength than malleable cast iron clips. Fist Grip clips provide a saddle for both the "live" and the "dead" end. Fewer forged clips are required for each termination than with malleable cast iron clips. Forged clips reduce the possibility of hidden defects that are sometimes present in malleable cast iron clips. Malleable cast iron clips should only be used in non-critical applications. ANSI, OSHA, and ASTM recommend only forged clips for critical applications.</p>	<p><i>Ask: Is the clip forged?</i></p> <p><i>Ask: Is an adequate cradle provided in the clip base for the wire rope?</i></p> <p>Malleable cast iron clips are sometimes improperly used as replacements for forged clips.</p>	<p>Crosby provides forged "Red" U-Bolt Clips and forged Fist Grip clips which meet or exceed Federal Specification Number FF-C-450 and are considered the industry standard.</p>
<p>FULL LINE The proper application of forged clips requires that the correct type, size, number, and installation instructions be used (See APPLICATION INFORMATION below for more information). Availability of a full range of sizes of forged U-bolt clips and forged Fist Grip clips are essential for design flexibility.</p>	<p><i>Ask: Do they have both Fist Grip and U-bolt clips available?</i></p> <p><i>Ask: Do they have a full range of forged wire rope clip sizes?</i></p> <p>No competitor has the full line of forged U-Bolt clips and Fist Grip clips that Crosby has.</p>	<p>Only Crosby provides forged "Red" U-Bolt Clips from 1/8" to 3-1/2"* and forged Fist Grip clips from 3/16" through 1-1/2".</p> <p>* The 3-1/2" base is a steel casting.</p>
<p>IDENTIFICATION The clip's size, manufacturer's logo, and a traceability code should be clearly embossed in the forging of the clip. These three elements are essential in developing total confidence in the product.</p>	<p><i>Ask: Is the manufacturer's name and size of clip clearly marked?</i></p> <p><i>Ask: Do they have a traceability system that is actively used in the manufacturing process?</i></p> <p>Most do not have a traceability system.</p>	<p>Crosby clearly embosses its logo, the size, and the Product Identification Code (PIC) into all Crosby "Red" U-bolt Clip bases and Fist Grip clips. Crosby's traceability system is actively used throughout the manufacturing of forged clips. The material analysis for each heat of steel, is verified within our own laboratory.</p>
<p>APPLICATION INFORMATION Detailed application information will assist you in the proper installation of wire rope clips. This information is most effective when provided at the point of application, as well as in supporting brochures and engineering information. The manufacturer must provide this specific information. Generic information will not provide all the needed application instructions. A formal application and warning system that attracts the attention of the user, clearly informs the user of the factors involved in the task, and informs the user with the proper application procedures as needed.</p>	<p><i>Ask: Does each clip have the application and warning information?</i></p> <p>Most competitors do not have application and warnings information with each clip.</p>	<p>Crosby provides detailed application and warning information for all forged clips. Each clip is individually bagged or tagged with the application and warning information. Testing and evaluation of special applications can be performed upon special request.</p>



Remember, "When buying Crosby, you're buying more than product, you're buying Quality."

Crosby Value Added

- Full Line: Crosby provides both forged “Red” U-Bolt Clips and forged Fist Grip Clips.
- Forged: Crosby “Red” U-Bolt Clips have forged bases on all sizes, except 3-1/2" (the 3-1/2" base is a steel casting). The entire clip is galvanized to resist corrosive and rusting action. Clip sizes 1/8" through 1-1/2" have U-Bolts with rolled threads which enhance the strength of the material and fatigue properties.
- Forged: Fist Grip Clips are forged, and the entire clip is galvanized. The double saddle design eliminates the possibility of incorrect installation. Designed as an integral part of the clip, the bolts are opposite one another (see G-429 example below). As result, the nuts can be installed in such a way as to enable the operator to swing the wrench in a full arc for ease of installation.
- Application Information: Application and warning information is available for both Crosby “Red” U-Bolt Clips and Fist Grip Clips. The Crosby Warning System is designed to attract the attention of the user, clearly inform the user of the factors involved in the task, and provide the user with proper application procedures. Each Crosby “Red” U-Bolt Clip and Fist Grip Clip is either bagged or tagged with appropriate application and warning information, thus ensuring that the information is available at the point of application for each and every clip during installation.
- Material Analysis: Crosby can provide certified material (mill) analysis for each production lot, traceable by the Product Identification Code (PIC). Crosby, through its own laboratory, verifies the analysis of each heat of steel.
- Testing: Crosby periodically audits the termination efficiencies of the “Red” U-Bolt Clips and Fist Grip Clips. Upon special request, Crosby will determine the efficiencies of clip assemblies when applied to special rope constructions and special applications.



G-450
Red-U-Bolt® Clip



G-429
Fist Grip Clip

Forged Wire Rope Clips



SEE APPLICATION AND WARNING INFORMATION

Para Español: www.thecrosbygroup.com

On Page 46

G-450



- Each base has a Product Identification Code (PIC) for material traceability, the name CROSBY or CG, and a size forged into it.
- Based on the catalog breaking strength of wire rope, Crosby wire rope clips have an efficiency rating of 80% for 3-4mm to 22mm sizes, and 90% for sizes 24-26mm through 90mm.
- Entire Clip-Galvanized to resist corrosive and rusting action.
- Sizes 1/8" through 2-1/2" (3 mm through 76mm) have forged bases.
- All Clips are individually bagged or tagged with proper application instructions and warning information.
- Clip sizes up through 1-1/2" (38mm) have rolled threads.
- Crosby products meet or exceed all requirements of ASME B30.26 including identification, ductility, design factor, proof load and temperature requirements. Importantly, Crosby products meet other critical performance requirements including fatigue life, impact properties and material traceability, not addressed by ASME B30.26.
- Look for the Red-U-Bolt®, your assurance of Genuine Crosby Clips.

Crosby Clips, all sizes except 68-72mm and 85-90mm meet the performance requirements of EN13411:2003. Crosby Clips, all sizes 6 mm and larger, meet the performance requirements of Federal Specification FF-C-450 TYPE 1 CLASS 1, except for those provisions required of the contractor. For additional information, see page 361.

G-450 Crosby® Clips

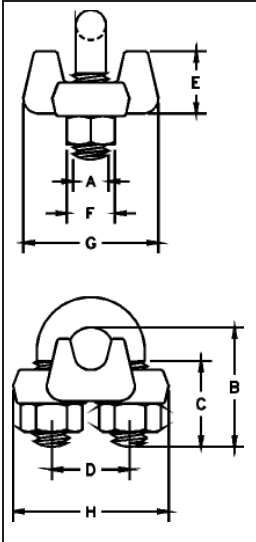

Rope Size (mm)*	G-450 Stock No.	Std. Package Qty.	Weight Per 100 (kg)	Dimensions (mm)							
				A	B	C	D	E	F	G	H
* 3-4	1010015	100	2.72	5.60	18.3	11.2	11.9	10.4	9.65	20.6	23.9
* 5	1010033	100	4.54	6.35	24.6	14.2	15.0	12.7	11.2	23.9	29.5
6-7	1010051	100	8.62	7.85	26.2	12.7	19.1	16.8	14.2	30.2	36.6
8	1010079	100	12.7	9.65	35.1	19.1	22.4	18.3	17.5	33.3	42.9
9-10	1010097	100	21.8	11.2	38.1	19.1	25.4	23.1	19.1	41.4	49.3
11	1010113	50	35.4	12.7	47.8	25.4	30.2	26.2	22.4	46.0	58.0
12-13	1010131	50	36.3	12.7	47.8	25.4	30.2	28.7	22.4	48.5	58.0
14-15	1010159	50	49.4	14.2	57.0	31.8	33.3	31.0	23.9	52.5	63.5
16	1010177	50	49.9	14.2	60.5	31.8	33.3	34.0	23.9	52.5	63.5
18-20	1010195	25	64	15.7	70.0	36.6	38.1	35.8	26.9	57.0	72.0
22	1010211	25	96	19.1	79.0	41.1	44.5	40.4	31.8	62.0	80.5
24-26	1010239	10	114	19.1	89.0	46.0	47.8	45.2	31.8	67.0	88.0
28-30	1010257	10	128	19.1	98.5	51.0	51.0	48.5	31.8	71.5	91.0
32-34	1010275	10	199	22.4	108	54.0	58.5	55.5	36.6	79.5	105
36	1010293	10	200	22.4	118	58.5	60.5	58.5	36.6	79.5	106
38	1010319	10	247	22.4	125	60.5	66.5	62.0	36.6	86.5	113
41-42	1010337	Bulk	319	25.4	135	66.5	70.0	67.5	41.4	92.0	121
44-46	1010355	Bulk	424	28.7	146	70.0	77.5	74.5	46.0	97.0	134
48-52	1010373	Bulk	590	31.8	164	76.0	86.0	83.5	51.0	113	149
56-58	1010391	Bulk	726	31.8	181	81.0	98.5	81.0	51.0	114	162
62-65	1010417	Bulk	862	31.8	195	87.5	105	93.5	51.0	103	168
** 68-72	1010435	Bulk	1043	31.8	211	90.5	111	124	51.0	127	175
75-78	1010453	Bulk	1406	38.1	233	98.5	121	119	60.5	149	194
** 85-90	1010426	Bulk	1814	38.1	273	114	140	152	60.5	157	213

* Electro-plated U-Bolt and Nuts. ** 70 mm and 89mm base is made of cast steel.

SS-450

- Each base has a Product Identification Code (PIC) for material traceability, the name CROSBY or CG, and a size forged into it.
- Entire clip is made from 316 Stainless Steel to resist corrosive and rusting action.
- All components are Electro-Polished.
- All Clips are individually bagged or tagged with proper application instructions and warning information.

SS-450 Stainless Steel Wire Rope Clips



Rope Size (mm)	SS-450 Stock No.	Std. Package Qty.	Weight Per 100 (kg)	Dimensions (mm)							
				A	B	C	D	E	F	G	H
3-4	1011250	Bulk	2.72	5.60	18.3	11.2	11.9	10.4	9.65	20.6	23.9
5	1011261	Bulk	4.54	6.35	24.6	14.2	15.0	12.7	11.2	23.9	29.5
6-7	1011272	Bulk	9.07	7.85	26.2	12.7	19.1	16.8	14.2	30.2	36.6
9-10	1011283	Bulk	21.3	11.2	38.1	19.1	25.4	23.1	19.1	41.4	49.3
12-13	1011305	Bulk	34.9	12.7	47.8	25.4	30.2	28.7	22.4	48.5	58.0
16	1011327	Bulk	48.1	14.2	60.5	31.8	33.3	34.0	23.9	52.5	63.5

Fist Grip® Wire Rope Clips

SEE APPLICATION AND WARNING INFORMATION
 Para Español: www.thecrosbygroup.com On Page 47

NEW STYLE FIST GRIP CLIPS 5 MM - 16 MM



Fist Grip wire clips meet or exceed the performance requirements of Federal Specification FF-C-450 Type III, Class 1, except for those provisions required of the contractor. For additional information, see page 361.

- Entire clip is Galvanized to resist corrosive and rusting action.
- Based on the catalog breaking strength of wire rope, Crosby wire rope clips have an efficiency rating of 80% for 3-4mm - 22mm sizes, and 90% for sizes 25mm through 90mm.
- Bolts are an integral part of the saddle. Nuts can be installed in such a way as to enable the operator to swing the wrench in a full arc for fast installation.
- All sizes have forged steel saddles.
- All Clips are individually bagged or tagged with proper application instructions and warning information.
- Crosby products meet or exceed all requirements of ASME B30.26 including identification, ductility, design factor, proof load and temperature requirements. Importantly, Crosby products meet other critical performance requirements including fatigue life, impact properties and material traceability, not addressed by ASME B30.26.
- Assembled with standard heavy hex nuts.

FIST GRIP® CLIPS 19 MM - 38 MM



3/16" - 5/8"

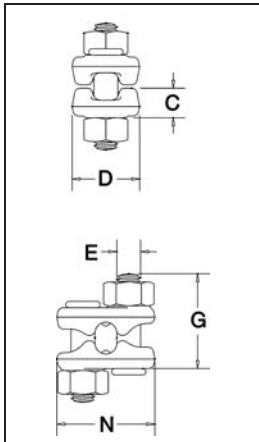

3/4" - 1-1/2"

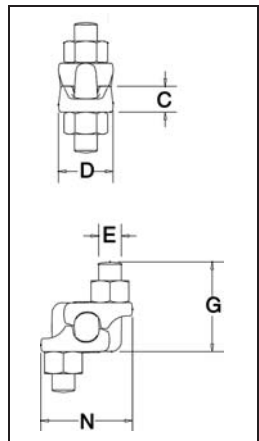

G-429 Fist Grip® Clips

Rope Size (mm)*	G-429 Stock No.	Std. Package Qty.	Weight Per 100 (kg)	Dimensions (mm)				
				C	D	E	G	N
5-7	1010471	100	10.4	10.2	23.9	9.65	32.5	36.6
8	1010499	100	12.7	11.9	26.9	9.65	37.3	39.1
10	1010514	50	18.1	13.0	26.9	11.2	46.0	45.2
11-13	1010532	50	28.1	15.0	31.8	12.7	55.5	54.6
14-16	1010550	50	46.7	18.3	38.1	16.0	68.5	65.3
18-20	1010578	25	79	21.8	46.0	19.1	74.5	67.8
22	1010596	25	102	24.6	53.8	19.1	84.0	72.6
24-26	1010612	10	136	28.7	57.0	19.1	94.5	77.7
28-30	1010630	10	181	32.5	60.5	22.4	107	87.4
32-34	1010658	10	181	34.0	63.5	22.4	108	90.4
36-40	1010676	Bulk	318	39.6	76.0	25.4	141	105

* Sizes through 16mm incorporate New Style design.

S-421T Wedge Sockets



SEE APPLICATION AND WARNING INFORMATION

Para Español: www.thecrosbygroup.com On Page 48

S-421T



Wedge sockets meet the performance requirements of Federal Specification RR-S-550D, Type C, except those provisions required of the contractor. Meets the performance requirements of EN13411-6:2003. For additional information, see page 361.

- Basket is cast steel.
- Wedge socket terminations have an efficiency rating of 80% based on the catalog strength of XXIP wire rope.
- Crosby products meet or exceed all requirements of ASME B30.26 including identification, ductility, design factor, proof load and temperature requirements. Importantly, Crosby products meet other critical performance requirements including fatigue life, impact properties and material traceability, not addressed by ASME B30.26.
- Individually magnetic particle inspected.
- Pin diameter and jaw opening allows wedge and socket to be used in conjunction with open swage and splter sockets.
- Secures the tail or "dead end" of the wire rope to the wedge, thus eliminates loss or "Punch out" of the wedge.
- Eliminates the need for an extra piece of rope, and is easily installed.
- The TERMINATOR™ wedge eliminates the potential breaking off of the tail due to fatigue.
- The tail, which is secured by the base of the clip and the wedge, is left undeformed and available for reuse.
- Incorporates Crosby's patented **QUIC-CHECK®** "Go" and "No-Go" feature cast into the wedge. The proper size rope is determined when the following criteria are met:
 - 1) The wire rope should pass thru the "Go" hole in the wedge.
 - 2) The wire rope should NOT pass thru the "No-Go" hole in the wedge.
- Utilizes standard Crosby Red-U-Bolt® wire rope clip.
- Standard S-421 wedge socket can be retrofitted with the new style TERMINATOR™ wedge.
- Available with Bolt, Nut, and Cotter Pin.
- U.S. patent 5,553,360 and foreign equivalents.

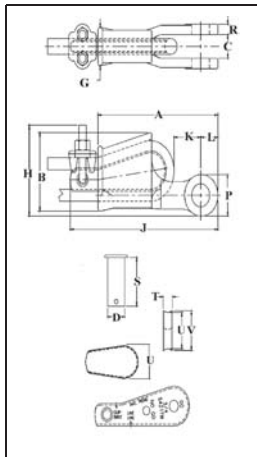

S-421T Wedge Sockets

Wire Rope Dia. (mm.)	S-421T Stock No.*	Weight Each (kg.)	S-421TW Stock No. Wedge Only	Wedge Only Weight Each (kg)	Optional G-4082 Bolt, Nut & Cotter	
					G-4082 Stock No.	G-4082 Weight Each (kg.)
9-10	1035000	1.44	1035555	.23	1092227	.17
11-13	1035009	2.79	1035564	.48	1092236	.31
14-16	1035018	4.40	1035573	.81	1092254	.52
18-19	1035027	6.58	1035582	1.18	1092281	.86
20-22	1035036	9.75	1035591	1.82	1092307	1.46
24-26	1035045	13.9	1035600	2.44	1092325	2.44
28	1035054	20.5	1035609	3.56	1092343	3.40
30-32	1035063	29.4	1035618	4.80	1092372	4.70

Wire Rope Dia. (mm.)*	S-421T Stock No.*	Dimensions (mm)														
		A	B	C	D	G	H	J†	K†	L	P	R	S	T	U	V
9-10	1035000	145	69.1	20.6	20.6	35.1	77.7	198	47.8	22.4	39.6	11.2	54.1	11.2	31.8	35.1
11-13	1035009	175	88.1	25.4	25.4	41.1	95.5	226	32.0	26.9	49.3	12.7	65.0	13.5	44.5	47.8
14-16	1035018	210	109	31.8	30.2	53.8	114	273	50.5	31.0	57.2	14.2	82.6	17.5	51.0	55.5
18-19	1035027	251	130	38.1	35.1	62.0	134	314	61.2	35.6	66.8	16.8	92.2	19.8	59.5	65.0
20-22	1035036	286	149	44.5	41.4	68.5	156	365	63.0	42.4	79.5	19.1	109	22.4	68.5	74.5
24-26	1035045	325	161	51.0	51.0	74.7	177	414	77.2	51.0	95.5	22.4	119	26.2	73.0	83.5
28	1035054	365	176	57.0	57.0	84.0	194	466	65.0	57.0	108	25.4	138	27.9	82.6	90.5
30-32	1035063	415	222	66.5	63.5	90.5	239	520	74.7	59.5	114	26.9	156	30.2	117	125

* S-421T TERMINATOR™ Assembly includes Socket, Wedge, Pin and Wire Rope Clip.

† Nominal

NOTE: For intermediate wire rope sizes, use next larger size socket.

US-422T Utility Wedge Sockets



SEE APPLICATION AND WARNING INFORMATION

Para Español: www.thecrosbygroup.com On Page 49

Wire Rope End Fittings

US-422T



Most sizes now incorporate the "TERMINATOR"™ design.

- Basket is cast steel.
- Wedge socket terminations have an efficiency rating of 80% based on the catalog strength of XXIP wire rope.
- Wedges are color coded for easy identification.
 - Blue - largest wire line size for socket.
 - Black - mid size wire line for socket.
 - 11 mm on US4
 - 14 mm on US5
 - Orange - smallest wire line size for socket.
- Cast into each wedge is the model number of the socket and the wire line size for which the wedge is to be used.
- Cast into each socket is the name "McKissick", "Crosby" or "CG", its model number and its wire line range.
- By simply changing out the wedge, each socket can be utilized for various wire line sizes (Ensure correct wedge is used for wire rope size).
- Load pin is forged and headed on one end.
- US-422 wedge sockets contain a hammer pad (lip) to assist in proper securement of termination.
- Crosby products meet or exceed all requirements of ASME B30.26 including identification, ductility, design factor, proof load and temperature requirements. Importantly, Crosby products meet other critical performance requirements including fatigue life, impact properties and material traceability, not addressed by ASME B30.26.
- UWO-422 Wedges are to be used only with the US-422 Wedge Socket Assemblies.

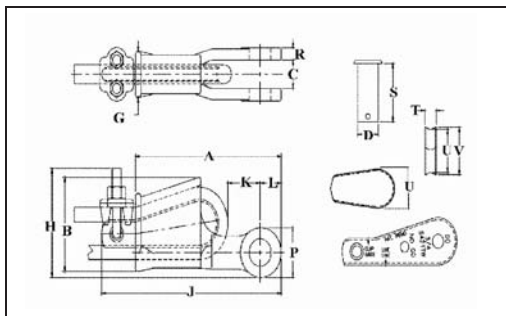

US-422T Utility Wedge Socket

Model No.	Wire Rope Size (mm)	US-422T Stock No.	Weight Each (kg)	Wedge Only Stock No.*	Weight Each (kg)	Dimensions (mm)														
						A	B	C	D	G	H	J	K	L	P	R	S	T	U	V
US4T	10	1044300	2.09	1047310	.27	173	90.2	25.4	25.4	41.4	71.4	214	35.1	26.9	49.3	12.7	64.3	11.2	48.5	54.4
US4T	11	1044309	2.09	1047301	.27	173	90.2	25.4	25.4	41.4	71.4	222	27.4	26.9	49.3	12.7	64.3	13.5	44.7	47.8
US4T	13	1044318	2.09	1047329	.27	173	90.2	25.4	25.4	41.4	71.4	222	25.9	26.9	49.3	12.7	64.3	13.5	44.7	47.8
US5T	13	1044327	3.86	1047338	.45	233	107	35.8	31.8	54.1	84.1	284	46.7	38.1	76.2	16.0	82.6	19.1	48.8	54.9
US5T	14	1044336	3.86	1047347	.45	233	107	35.8	31.8	54.1	84.1	291	61.0	38.1	76.2	16.0	82.6	17.5	50.8	55.4
US5T	16	1044345	3.86	1047356	.45	233	107	35.8	31.8	54.1	84.1	291	59.4	38.1	76.2	16.0	82.6	17.5	50.8	55.4
US6T	16	1044354	4.26	1047365	.64	240	119	38.1	31.8	56.9	92.2	303	63.0	38.1	76.2	14.2	82.6	22.4	60.5	69.9
US6T	19	1044363	4.26	1047374	.64	240	119	38.1	31.8	56.9	92.2	300	51.6	38.1	76.2	14.2	82.6	22.4	54.1	66.8
US8AT	16	1044372	9.0	1047383	1.9	269	144	46.0	41.4	60.5	140	335	48.5	38.9	73.2	19.1	105	17.5	82.8	88.9
US8AT	19	1044381	9.3	1047392	2.2	269	144	46.0	41.4	60.5	148	344	60.5	38.9	73.2	19.1	105	19.8	79.2	85.9
US7 †	22	1038580	7.48	1046674	1.18	286	130	33.3	31.8	68.3	-	-	65.0	41.4	82.8	16.8	82.6	26.9	53.8	65.0
US7 *	25	1038589	7.48	1046683	1.18	286	130	33.3	31.8	68.3	-	-	65.0	41.4	82.8	16.8	82.6	26.9	47.8	60.5
US8T	22	1044404	14.3	1047425†	3.4	324	177	46.0	41.4	77.7	183	407	72.9	41.9	79.2	19.1	105	22.4	98.6	106
US8T	25	1044417	14.7	1047431	3.9	324	177	46.0	41.4	77.7	186	417	58.9	41.9	79.2	19.1	105	26.2	95.5	103
US10T	28	1044426	25.1	1047440	5.7	405	219	46.0	41.4	90.7	232	501	82.8	55.6	111	19.1	105	27.7	121	129
US10T	32	1044435	26.3	1047459	6.8	405	219	46.0	41.4	90.7	239	514	71.9	55.6	111	19.1	105	30.2	117	125
US11T	28	1044444	27.5	1047468	5.7	415	222	66.5	63.5	90.4	232	507	85.6	59.4	114	26.9	156	27.7	121	129
US11T	32	1044453	29.4	1047477	6.8	415	222	66.5	63.5	90.4	239	520	74.7	59.4	114	26.9	156	30.2	117	125

* UWO-422T "TERMINATOR"™ Style
 † Non-"TERMINATOR"™ Style

Button Spelter Sockets

SB-427



- Available in six sizes from 13mm to 38mm.
- Button Spelter terminations have a 100% efficiency rating, based on the catalog strength of the wire rope.
- Designed for use with mobile cranes. Can be used to terminate high performance, rotation resistant ropes, and standard 6 strand ropes.
- Easy to install assembly utilizes Crosby® WIRELOCK® socketing compound.
- Sockets and buttons are re-usable.
- Replacement buttons and sockets are available.

Button Spelter Sockets

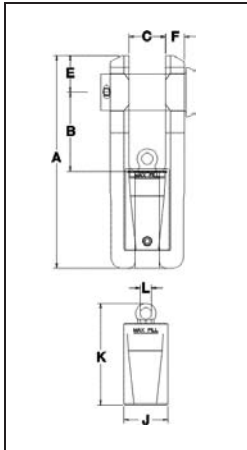

Wire Rope Size		SB-427 Stock No.	Weight Each (kg)	Socket Only Stock No.	Button Only Stock No.	Dimensions (mm)									
(in.)	(mm)					A	B	C	D	E	F	J	K	L	
1/2 - 5/8	13-16	1052005	2.76	1052107	1052309	183	67.6	32.5	30.2	31.0	15.7	38.1	88.9	6.35	
5/8 - 3/4	16-19	1052014	4.67	1052116	1052318	217	79.2	38.8	35.1	36.6	19.1	44.5	109	9.65	
3/4 - 7/8	19-23	1052023	7.75	1052125	1052327	254	92.0	45.2	41.1	42.9	22.4	52.3	121	9.65	
7/8 - 1	22-26	1052032	13.24	1052134	1052336	298	111	51.6	51.0	51.0	26.2	61.9	143	15.7	
1-1/8 - 1-1/4	28-32	1052041	20.86	1052143	1052345	351	127	64.3	57.2	63.5	28.2	74.7	180	19.1	
1-3/8 - 1-1/2	35-38	1052050	35.38	1052152	1052354	424	152	77.0	69.9	79.2	32.3	91.9	205	19.1	

Wirelock Requirements

Wire Rope Size		WIRELOCK Required (cc)	WIRELOCK Stock No.	WIRELOCK Kit Size (cc)
(in.)	(mm)			
1/2 - 5/8	13-16	35	1039602	100
5/8 - 3/4	16-19	60	1039602	100
3/4 - 7/8	19-23	100	1039602	100
7/8 - 1	22-26	140	1039602 *	100
1-1/8 - 1-1/4	28-32	250	1039604	250
1-3/8 - 1-1/2	35-38	420	1039606	500

* 2 kits required.

Mooring Sockets

G-517



- Wide range of sizes available:
 - 50 mm through 92 mm Wire Line
- "M-Line" socket terminations have a 100% efficiency rating, based on the minimum breaking load of the wire rope.
- Galvanized finish
- Designed for today's higher strength classes of wire rope.
- Design of bail allows for easy connection to shackles and other connecting links.
- Socket design utilizes features to keep cone from rotating.

G-517 "M-Line" Mooring Sockets

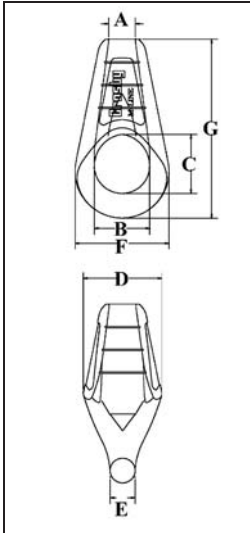

Rope Dia. (mm)	G-517 Stock No.	Weight Each (kg.)	Dimensions (mm)						
			A	B	C	D	E	F	G
50-54	1005002	25.8	63.5	121	133	178	53.1	210	407
57-60	1005020	34.5	70.5	133	146	196	58.7	233	455
64-67	1005048	47.6	77.5	149	170	217	68.3	257	505
70-73	1005066	62.6	84.5	165	181	237	76.2	282	549
76-79	1005084	87.5	89.0	184	197	262	82.6	313	597
82-86	1005105	104	98.5	194	222	277	88.9	334	654
88-92	1005123	127	105	203	230	298	93.7	355	692

Open Spelter Sockets

G-416 / S-416



- Forged Steel Sockets thru 38 mm, cast alloy steel 40 mm thru 100 mm.
- Spelter socket terminations have an efficiency rating of 100%, based on the catalog strength of wire rope. Ratings are based on recommended use with 6 x 7, 6 x 19, or 6 x 37, IPS or XIP (EIP), XXIP (EEIP), RRL, FC, or IWRC wire rope.

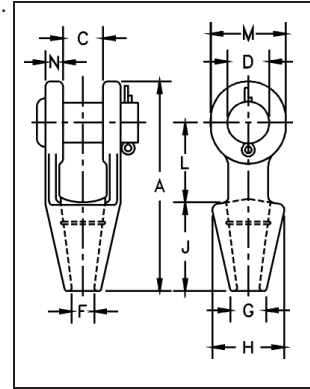

Open Grooved Sockets meet the performance requirements of Federal Specification RR-S-550D, Type A, except for those provisions required of the contractor. For additional information, see page 361.

NOTICE:

All cast steel sockets 40 mm and larger are magnetic particle inspected and ultrasonic inspected. Proof testing available on special order. Drawing illustrates one groove used on sockets 6 mm thru 19 mm. Sizes 22 mm thru 38 mm use 2 grooves. Sizes 40 mm and larger use 3 grooves.

G-416 / S-416 Open Spelter Sockets

Rope Dia. (mm)*	Structural Strand Dia. (mm)	Stock No.		Weight Each (kg)	Dimensions (mm)									
		G-416 Galv.	S-416 S.C.		A	C	D	F	G	H	J	L	M	N
6-7	-	1039619	1039628	.50	116	19.1	17.5	9.65	17.5	39.6	57.0	39.6	33.3	9.10
8-10	-	1039637	1039646	.59	123	20.6	20.6	12.7	20.6	42.9	57.0	44.5	38.1	11.2
11-13	-	1039655	1039664	1.02	141	25.4	25.4	14.2	23.9	47.8	63.5	51.0	47.8	12.7
14-16	12-13	1039673	1039682	1.63	171	31.8	30.2	17.5	28.7	57.0	76.0	63.5	57.0	14.2
18	14-16	1039691	1039708	2.64	202	38.1	35.1	20.6	31.8	66.5	89.0	76.0	66.5	15.7
20-22	18-19	1039717	1039726	4.38	235	44.5	41.4	23.9	38.1	82.5	102	89.0	79.5	20.3
24-26	20-22	1039735	1039744	7.03	268	51.0	51.0	28.7	44.5	95.5	114	102	95.5	22.4
28-30	24-26	1039753	1039762	9.75	300	57.0	57.0	31.8	51.0	105	127	117	105	25.4
32-35	28	1039771	1039780	14.1	335	63.5	63.5	38.1	57.0	121	140	127	121	28.7
38	30-32	1039799	1039806	21.4	384	76.0	70.0	41.4	70.0	133	152	152	137	30.2
* 40-42	33-35	1039815	1039824	24.9	413	76.0	76.0	44.5	76.0	140	165	165	146	33.3
* 44-48	36-40	1039833	1039842	37.2	464	89.0	89.0	51.0	79.5	162	191	178	165	39.6
* 50-54	42-45	1039851	1039860	59	546	102	95.5	57.0	95.5	187	216	229	178	46.0
* 56-60	46-48	1039879	1039888	76	597	114	108	63.5	102	210	229	254	197	54.0
* 64-67	50-54	1041633	1041642	114	648	127	121	73.0	114	235	248	274	216	60.5
* 70-73	56-62	1041651	1041660	143	692	133	127	79.0	124	267	279	279	229	73.0
* 75-80	64-67	1041679	1041688	172	737	146	133	86.0	133	282	305	287	241	76.0
* 82-86	70-73	1041697	1041704	197	784	159	140	92.0	146	302	330	300	254	79.0
* 88-92	76-80	1041713	1041722	255	845	171	152	98.5	165	314	356	318	274	82.5
* 94-102	-	1041731	1041740	355	921	191	178	108	184	346	381	343	318	89.0

* Cast Alloy Steel.

Closed Spelter Sockets

G-417 / S-417



- Forged Steel Sockets thru 38 mm, cast alloy steel 40 mm thru 100 mm.
- Spelter socket terminations have an efficiency rating of 100%, based on the catalog strength of wire rope. Ratings are based on the recommended use with 6 x 7, 6 x 19 or 6 x 37, IPS or XIP (EIP) , XXIP (EEIP), RRL, FC or IWRC wire rope.

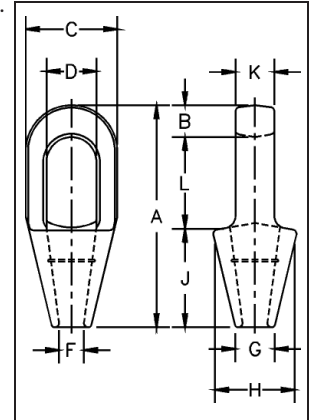

Closed grooved Sockets meet the performance requirements of Federal Specification RR-S-550D, Type B, except for those provisions required of the contractor. For additional information, see page 361.

NOTICE:

All cast steel sockets 40 mm and larger are magnetic particle inspected and ultrasonic inspected. Proof testing available on special order. Drawing illustrates one groove used on sockets 6 mm thru 19 mm. Sizes 22 mm thru 38 mm use 2 grooves. Sizes 40 mm and larger use 3 grooves.

G-417 / S-417

Closed Spelter Sockets

Rope Dia. (mm) †	Structural Strand Dia. (mm)	Stock No.		Weight Each (kg)	Dimensions (mm)									
		G-417 Galv.	S-417 S.C.		A	B	C	D*	F	G	H	J	K	L
6-7	-	1039897	1039904	.23	116	12.7	39.6	22.4	9.65	17.5	39.6	57.2	12.7	46.0
8-10	-	1039913	1039922	.34	125	15.8	42.9	24.6	12.7	20.6	42.9	57.2	17.5	52.3
11-13	-	1039931	1039940	.68	140	17.5	51.0	29.5	14.2	23.9	51.0	63.5	22.4	58.7
14-16	12-13	1039959	1039968	1.13	162	20.6	67.0	35.8	17.5	30.2	67.0	76.2	25.4	65.0
18	14-16	1039977	1039986	1.92	194	26.9	76.2	42.2	22.4	33.3	70.0	89.0	31.8	77.7
20-22	18-19	1039995	1040000	3.28	226	33.3	92.0	49.3	25.4	38.1	82.5	102	38.1	90.5
24-26	20-22	1040019	1040028	4.76	254	36.6	105	58.5	28.7	44.5	95.5	114	44.5	103
28-30	24-26	1040037	1040046	6.46	283	39.6	114	65.0	31.8	51.0	105	127	51.0	116
32-35	28	1040055	1040064	8.95	309	41.4	127	71.0	38.1	58.5	119	138	56.5	129
38	30-32	1040073	1040082	13.24	355	49.3	137	81.0	41.4	70.5	132	151	62.5	155
† 40-42	33-35	1040091	1040108	16.32	390	54.0	146	82.5	44.5	76.2	140	165	70.0	171
† 44-48	36-40	1040117	1040126	25.96	445	55.5	171	95.5	51.0	79.5	162	191	76.2	198
† 50-54	42-45	1040135	1040144	35.83	505	62.0	194	111	57.2	95.5	187	216	82.5	224
† 56-60	46-48	1040153	1040162	47.62	546	70.0	216	127	66.8	105	210	229	92.0	248
† 64-67	50-54	1041759	1041768	63.50	597	79.5	241	140	74.5	114	235	248	102	270
† 70-73	56-62	1041777	1041786	99.79	645	79.5	273	159	79.5	124	259	279	124	286
† 75-80	64-67	1041795	1041802	125	689	85.6	292	171	86.0	133	292	305	133	298
† 82-86	70-73	1041811	1041820	142	743	102	311	184	92.0	146	311	330	146	311
† 88-92	76-80	1041839	1041848	181	787	102	330	197	98.5	160	330	356	159	330
† 94-102	-	1041857	1041866	246	845	108	362	216	108	184	362	381	178	356

* Diameter of pin must not exceed pin used on companion 416 socket. Reference adjacent page "D" dimension.

† Cast Alloy Steel.

National Steel Swaging Sleeves



S-505

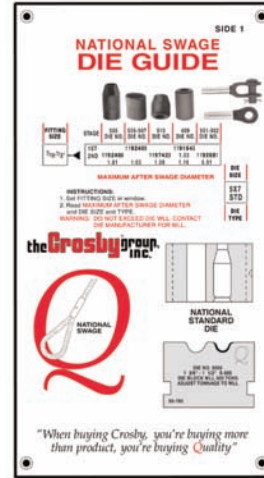

The National Die Guide will assist you in selecting the proper dies to meet your swaging needs.

- For Flemish eye wire rope splicing.
- Designed for low temperature toughness.
- Resists cracking when swaged (equals or exceeds stainless steel sleeves).
- Special processed low carbon steel.
- "COLD TUFF"® for better swageability.

- Can be stamped for identification after swaging without concern for fractures when following these directions.
 - Use round corner stamps to a maximum depth of 0.015 in. (1/64). The area for stamping should be on the side of the sleeve in the plane of the sling eye, and no less than 0.250 in. (1/4) from either end of the sleeve.
- Standard Steel Sleeve terminations have efficiency ratings as follows based on the catalog strength of wire rope.

Size (in.)	S-505 Termination Efficiency	
	Type of Wire Rope *	
	IWRC	FC
1/4 - 1	96%	93%
1-1/8 - 2	92%	89%
2-1/8 and Larger	90%	87%

** NOTE: S-505 Standard Sleeves are recommended for use with 6 x 19 or 6 x 37, IPS or XIP (EIP), XXIP (EEIP), RRL, FC or IWRC wire rope.

Before using any National Swage fitting with any other type lay, construction or grade of wire rope, it is recommended that the termination be destructive tested and documented to prove the adequacy of the assembly to be manufactured.

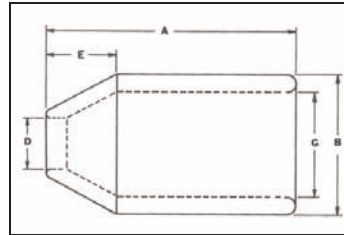

NOTE: See Page 37 for dimensional information

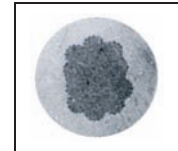

"Cross Section of Swaged Sleeve"

QUIC-PASS®

National QUIC-PASS® Swaging System "The Next Generation in Swaging Systems"

The QUIC-PASS® swaging system allows "Flemish style" wire rope terminations to be swaged in only two passes. This is accomplished while maintaining currently published efficiency ratings and utilizing National Swage S-505 Standard "COLD TUFF"® Steel Sleeves.

- Allows the swaging process to be completed in just two passes. Resulting in a 50-75% reduction in the number of passes required with conventional swaging systems.
- Allows the dies to close completely with each pass, resulting in...
 - An increase in overall swaging process efficiencies (the job can be performed quicker).
 - A reduction in the complexity of swaging (the concern for excess flashing between dies has been eliminated).
 - A reduction in training time needed for operators (more user friendly).
- The finished sleeve has a "Hex" appearance that provides a QUIC-CHECK® look to determine if the termination has been swaged and provides a flat surface that allows for ease of I.D. stamping on the finished sleeve.

For additional swaging information, please refer to the National Swaging Brochure.

National Steel Swaging Sleeves

Wire Rope End Fittings

S-505 COLD TUFF® Standard Steel Sleeves

S-505 Standard Steel Sleeve Specifications											Press / Die Data		
S-505 Stock No.	Rope Size (mm)	Weight Per 100 (kg)	Pkg. Qty.	Before Swage Dimensions (mm)					Maximum After Swage Dimensions (mm)		Standard Round Dies		QUIC-PASS Dies
				A	B	D	E	G	Standard Die	QUIC-PASS Die	Die Description	Standard Die Stock No.	QUIC-PASS Die Stock No.
1041063	6-7	3.60	250	25.4	16.8	7.88	7.12	11.9	14.5	14.4	1/4 Taper	1197528	1923530
1041090	8	4.08	200	38.1	23.1	9.66	11.2	15.8	19.1	19.5	3/8 Taper	1192364	1923551
1041107	9-10	5.44	100	38.1	23.1	11.9	9.91	16.8	19.1	19.5	3/8 Taper	1192364	1923551
1041125	11	13.6	50	51.0	31.0	13.5	16.5	21.6	25.7	25.8	1/2 Taper	1192408	1923572
1041143	13	13.2	50	51.0	31.0	16.0	14.2	23.1	25.7	25.8	1/2 Taper	1192408	1923572
1041161	14	30.8	25	70.0	37.3	17.8	16.0	26.2	31.5	31.7	5/8 Taper	1192444	1923593
1041189	16	25.9	25	70.0	37.3	19.1	16.0	27.7	31.5	31.7	5/8 Taper	1192444	1923593
1041205	18-19	40.0	20	81.0	43.7	23.1	21.3	32.5	37.1	37.5	3/4 Taper	1192462	1923614
1041223	22	62	10	90.5	51.5	26.2	25.4	38.9	42.7	44.1	7/8 Taper	1192480	1923635
1041241	25-26	89	10	102	58.0	29.5	28.6	43.7	49.0	49.7	1 Taper	1192505	1923656
1041269	28-29	118	Bulk	122	63.5	32.5	31.8	49.3	54.1	55.1	1-1/8 Open 1st Stage 2nd Stage	1192523 1192541	1923677
1041287	31-32	154	Bulk	132	70.5	36.5	35.8	55.0	58.9	61.1	1-1/4 Open 1st Stage 2nd Stage	1192621 1192587	1923698
1041303	34-35	195	Bulk	148	76.0	39.7	39.7	60.5	64.0	66.3	1-3/8 Open 1st Stage 2nd Stage	1192667 1192621	1923717
1041321	37-38	226	Bulk	159	82.5	42.9	42.9	67.0	69.0	72.0	1-1/2 Open 1st Stage 2nd Stage	1192649 1192667	1923736

S-505 Standard Steel Sleeve Specifications											Press/ Die Data				
S-505 Stock No.	Rope Size (mm)	Weight Per 100 (kg)	Pkg. Qty.	Before Swage Dimensions (mm)					Maximum After Swage Dimensions (mm)	Die Desc.	Stock No.				
				A	B	D	E	G			500 Tons 1000 Tons 1500 Tons 5x7	Front Load		Side Load	
												1500 ton 6x12	3000 ton 6x12	1500 ton 6x12	3000 ton 6x12
1041349	44-45	367	Bulk	184	97.5	49.2	50.0	79.5	78.7	1-3/4 Open 1st Stage 2nd Stage	1192685 1192701	-	-	-	-
1041367	50-52	510	Bulk	216	111	57.0	57.0	92.0	90.4	2 Open 1st Stage 2nd Stage	1192729 1192747	-	-	-	-
1041385	56-57	862	Bulk	243	128	63.5	64.5	102	105	2-1/4 Open 1st Stage 2nd Stage	1192765 1192783	1191089 1191043	1191089 1191043	-	1195085 1195067
1041401	62-64	1043	Bulk	267	140	70.0	71.5	114	114	2-1/2 Open 1st Stage 2nd Stage	-	1191061 1191089	1191061 1191089	1195370 1195469	1195076 1195085
1041429	68-70	1270	Bulk	292	146	76.0	78.5	121	119	2-3/4 Open 1st Stage 2nd Stage	-	1191034 1191052	1191034 1191052	1195389 1195478	1195094 1195101
1041447	75-76	1334	Bulk	305	152	82.5	86.0	127	126	3 Open 1st Stage 2nd Stage	-	1193201 1193229	1193201 1193229	1195398 1195487	1195110 1195129
1041483	87-89	2105	Bulk	356	178	98.5	100	148	147	3-1/2 Open 1st Stage 2nd Stage	-	-	1193247 1193265	-	1195138 1195147
1041492	93-95	2495	Bulk	381	191	103	108	160	158	3-3/4 Open 1st Stage 2nd Stage	-	-	1191114 1191132	-	1195263 1195272
1041508	100-105	3130	Bulk	406	206	111	114	173	170	4 Open 1st Stage 2nd Stage	-	-	1191150 1191178	-	1195156 1195165
1041526	112-114	4536	Bulk	457	232	124	129	195	189	4-1/2 Open 1st Stage 2nd Stage	-	-	1191187 1191203	-	1195174 1195183

Open Swage Sockets

QUIC-CHECK®



S-501



- Forged from special bar quality carbon steel, suitable for cold forming.
- Swage Socket terminations have an efficiency rating of 100% based on the catalog strength of wire rope.
- Hardness controlled by spheroidize annealing.
- Stamp for identification after swaging without concern for fractures (as per directions in National Swaging Brochure).
- Swage sockets incorporate a reduced machined area of the shank which is equivalent to the proper "After Swage" dimension. Before swaging, this provides for an obvious visual difference in the shank diameter. After swaging, a uniform shank diameter is created allowing for a QUIC-CHECK® and permanent visual inspection opportunity.
 - Designed to quickly determine whether the socket has been through the swaging operation and assist in field inspections, it does not eliminate the need to perform standard production inspections which include gauging for the proper "After Swage" dimensions or proof loading.
- U.S. Patent 5,152,630 and foreign equivalents.

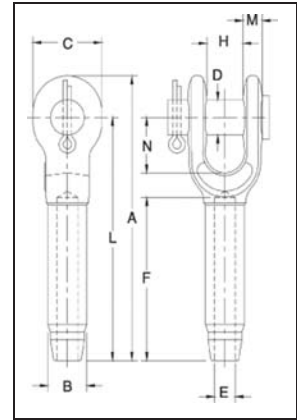

NOTE: S-501 Swage Sockets are recommended for use with 6 x 19 or 6 x 37, IPS or XIP (EIP), XXIP (EEIP), RRL, FC or IWRC wire rope. Before using any National Swage fitting with any other type lay, construction or grade of wire rope, it is recommended that the termination be destructive tested and documented to prove the adequacy of the assembly to be manufactured. In accordance with ANSI B30.9, all slings terminated with swage sockets shall be proof loaded.*

S-501 Open Swage Sockets

S-501 Open Socket Specifications														Press / Die Data					
S-501 Stock No.	Rope Size (mm)*	Weight Each (kg)	Before Swage Dimensions											Max. After Swage Dim. (mm)	Die Description	Stock No.		Side Load	
			A	B	C	D	E	F	H	L	M	N	500 1000 1500 Ton 5 x 7			1500 3000 Ton 6 x 12	1500 Ton 6 x 12	3000 Ton 6 x 12	
1039021	6	0.24	122	12.7	35.1	17.5	6.85	54.0	17.5	102	9.65	38.1	11.7	1/4 Socket	1192845	-	-	-	
1039049	8	0.51	159	19.6	41.1	20.6	8.65	81.0	20.6	135	11.9	44.5	18.0	5/16-3/8 Socket	1192863	-	-	-	
1039067	9-10	0.59	159	19.6	41.1	20.6	10.4	81.0	20.6	135	11.9	44.5	18.0	5/16-3/8 Socket	1192863	-	-	-	
1039085	11-12	0.94	198	24.9	51.0	25.4	12.2	108	25.4	170	14.2	51.0	23.1	7/16-1/2 Socket	1192881	-	-	-	
1039101	13	0.94	198	24.9	51.0	25.4	14.0	108	25.4	170	14.2	51.0	23.1	7/16-1/2 Socket	1192881	-	-	-	
1039129	14	2.12	241	31.8	60.5	30.2	15.5	135	31.8	207	17.3	57.0	29.5	9/16-5/8 Socket	1192907	-	-	-	
1039147	16	2.05	241	31.8	60.5	30.2	17.0	135	31.8	207	17.3	57.0	29.5	9/16-5/8 Socket	1192907	-	-	-	
1039165	18-20	3.62	294	39.4	70.0	35.1	20.3	162	38.1	254	19.8	70.0	36.1	3/4 Socket	1192925	-	-	-	
1039183	22	5.23	341	43.2	79.5	41.1	23.9	189	44.5	295	23.9	82.5	39.4	7/8 Socket	1192943	-	-	-	
1039209	24-26	8.07	393	50.5	93.5	51.0	26.9	216	51.0	340	26.9	95.5	45.7	1 Socket	1192961	-	-	-	
1039227	28	11.5	440	57.0	103	57.0	30.2	243	57.0	381	30.2	108	52.0	1-1/8 Socket	1192989	-	-	-	
1039245	32	16.1	484	64.5	114	63.5	33.8	270	63.5	419	31.0	121	58.5	1-1/4 Socket	1193005	-	-	-	
1039263	34-36	19.8	532	71.0	127	63.5	36.8	297	63.5	461	35.1	133	65.0	1-3/8 Socket	1193023	-	-	-	
1039281	38-40	26.5	581	78.0	140	70.0	40.1	324	76.0	502	42.9	146	71.5	1-1/2 Socket	1193041	1191267	1195355	1195192	
1039307	44	40.3	676	86.0	170	89.0	47.2	378	89.0	584	53.5	171	77.5	1-3/4 Socket	1193069	1191276	1195367	1195209	
1042767	48-52	66	799	100	203	95.5	53.5	432	102	683	60.0	203	90.5	2 Socket	1193087	1191294	1195379	1195218	

* Maximum Proof Load shall not exceed 50% of XXIP rope catalog breaking strength.

Closed Swage Sockets



S-502



- Forged from special bar quality carbon steel, suitable for cold forming.
- Swage Socket terminations have an efficiency rating of 100% based on the catalog strength of wire rope.
- Hardness controlled by spheroidize annealing.
- Stamp for identification after swaging without concern for fractures (as per directions in National Swaging Brochure).
- Swage sockets incorporate a reduced machined area of the shank which is equivalent to the proper "After Swage" dimension. Before swaging, this provides for an obvious visual difference in the shank diameter. After swaging, a uniform shank diameter is created allowing for a **QUIC-CHECK®** and permanent visual inspection opportunity.
 - Designed to quickly determine whether the socket has been through the swaging operation and assist in field inspections, it does not eliminate the need to perform standard production inspections which include gauging for the proper "After Swage" dimensions or proof loading.
- U.S. Patent 5,152,630 and foreign equivalents.

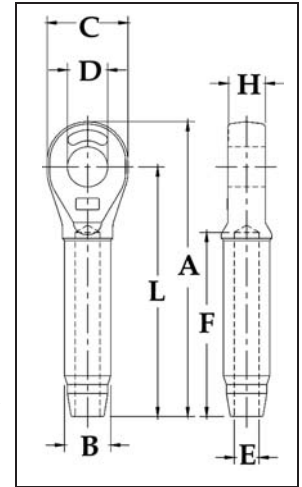

NOTE: S-502 Swage Sockets are recommended for use with 6 x 19 or 6 x 37, IPS or XIP (EIP), XXIP (EEIP), RRL, FC or IWRC wire rope. Before using any National Swage fitting with any other type lay, construction or grade of wire rope, it is recommended that the termination be destructive tested and documented to prove the adequacy of the assembly to be manufactured. In accordance with ANSI B30.9, all slings terminated with swage sockets shall be proof loaded.*

S-502 Closed Swage Sockets

S-502 Closed Socket Specifications												Press / Die Data				
S-502 Stock No.	Rope Size (mm) [†]	Weight Each (kg)	Before Swage Dimensions								Max. After Swage Dim. (mm)	Die Description	Stock No.		Side Load	
			A	B	C	D	E	F	H	L			500 Ton 5 x 7	1500 Ton 6 x 12	1500 Ton 6 x 12	3000 Ton 6 x 12
1039325	6	0.15	109	12.7	35.1	19.1	6.85	54.0	12.7	89.0	11.7	1/4 Socket	1192845	-	-	-
1039343	8	0.34	138	19.6	41.1	22.4	8.65	81.0	17.0	114	18.0	5/16-3/8 Socket	1192863	-	-	-
1039361	9-10	0.33	138	19.6	41.1	22.4	10.4	81.0	17.0	114	18.0	5/16-3/8 Socket	1192863	-	-	-
1039389	11-12	0.64	176	24.9	51.0	26.9	12.2	108	21.8	146	23.1	7/16-1/2 Socket	1192881	-	-	-
1039405	13	0.64	176	24.9	51.0	26.9	14.0	108	21.8	146	23.1	7/16-1/2 Socket	1192881	-	-	-
1039423	14	1.32	220	31.8	60.5	31.8	15.5	135	28.7	184	29.5	9/16-5/8 Socket	1192907	-	-	-
1039441	16	1.29	220	31.8	60.5	31.8	17.0	135	28.7	184	29.5	9/16-5/8 Socket	1192907	-	-	-
1039469	18-20	2.27	261	39.4	73.0	36.6	20.3	162	33.3	219	36.1	3/4 Socket	1192925	-	-	-
1039487	22	3.08	303	43.2	79.0	42.9	23.9	189	38.1	257	39.4	7/8 Socket	1192943	-	-	-
1039502	24-26	4.72	344	50.5	92.0	52.5	26.9	216	44.5	292	45.7	1 Socket	1192961	-	-	-
1039520	28	6.72	382	57.0	102	58.5	30.2	243	51.0	324	52.0	1-1/8 Socket	1192989	-	-	-
1039548	32	9.78	430	64.5	114	65.0	33.8	270	57.0	365	58.5	1-1/4 Socket	1193005	-	-	-
1039566	34-36	12.9	473	71.0	127	65.0	36.8	297	57.0	400	65.0	1-3/8 Socket	1193023	-	-	-
1039584	38-40	17.3	511	78.0	140	71.5	40.1	324	63.5	432	71.5	1-1/2 Socket	1193041	1191267	1193355	1195192
1039600	44	23.1	598	86.0	159	90.5	47.2	378	76.0	508	77.5	1-3/4 Socket	1193069	1191276	1195367	1195209
1042589	48-52	40.5	702	100	184	96.5	53.5	432	82.5	584	90.5	2 Socket	1193087	1191294	1195379	1195218

* Maximum Proof Load shall not exceed 50% of XXIP rope catalog breaking strength.

National Swage Buttons

S-409



- Swage Button terminations have an efficiency rating of 98% based on the catalog strength of wire rope.
- Special processed, low carbon steel.
- COLD TUFF® for better swageability.
- Stamp for identification after swaging without concern for fractures (as per directions in National Swaging Brochure).

NOTE: S-409 Buttons are recommended for use with 6 x 19 or 6 x 37, IPS or XIP (EIP), RRL, FC or IWRC wire rope. Before using any National Swage fitting with any other type lay, construction or grade of wire rope, it is recommended that the termination be destructive tested and documented to prove the adequacy of the assembly to be manufactured.

S-409 COLD TUFF® Buttons

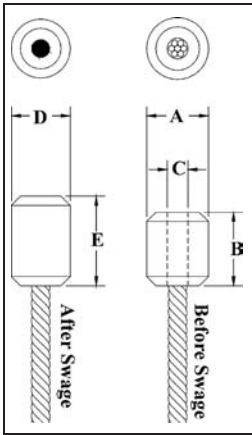

S-409 Steel Swage Button Specifications									Press / Die Data	
S-409 Stock No.	Size No.	Rope Size (mm)	Weight Per 100 (kg)	Before Swage Dimensions			After Swage Dimensions		Die Desc.	Stock No. 500 Tons 1000 Tons 1500 Tons 5 x 7
				A	B	C	D Maximum After Swage Dimensions	E Length*		
1040171	1 SB	3	.91	11.2	12.7	3.55	10.2	15.5	1/8 - 1/4 Button	1191621
1040215	3 SB	5	1.81	14.2	17.8	5.10	13.2	21.3	1/4 1st Stage	1197528
1040251	5 SB	6-6.5	3.63	16.0	26.9	7.60	14.7	30.5	1/8 - 1/4 Button	1191621
1040297	7 SB	8	7.26	22.4	28.7	9.15	19.6	33.8	3/8 1st Stage	1192364
1040313	8 SB	9-10	6.80	22.4	37.6	10.7	19.6	42.9	3/8 1st stage	1192364
1040331	9 SB	11	13.6	28.7	41.4	12.2	26.2	49.3	1/2 1st Stage	1192408
1040359	10 SB	13	22.7	33.3	48.0	14.0	29.5	55.0	5/8 socket	1192907
1040377	11 SB	14	31.8	36.6	51.5	15.5	32.8	61.0	9/16 -5/8 Button	1191665
1040395	12 SB	16	45.4	39.6	61.5	17.0	36.1	73.5	3/4 Socket	1192925
1040411	13 SB	18-20	59	42.9	69.5	20.1	39.4	82.5	3/4 1st Stage	1192462
1040439	14 SB	22	100	51.0	83.0	23.9	45.7	98.0	7/8 1st Stage	1192480
1040457	15 SB	25-26	141	57.0	93.0	26.9	52.0	111	1 1st Stage	1192505
1040475	16 SB	28-29	204	65.0	103	30.2	58.5	122	1-1/8 1st Stage	1192523
1040493	17 SB	31-32	295	71.5	116	33.8	65.0	138	1-3/8 Socket	1193023

* NOTE: Length is measured from outside end of termination.

National Swage Duplex Sleeves

S-506



- For turnback wire rope splicing.
- Special processed low carbon steel.
- Turnback terminations have efficiency ratings of 94% based on the catalog strength of wire rope.
- Designed for lower temperature toughness.
- Resists cracking when swaged (equals or exceeds stainless steel sleeves).
- COLD TUFF® for better swageability.
- Stamp for identification after swaging without concern for fractures (as per directions in National Swaging Brochure).

NOTE: S-506 Duplex sleeves are recommended for use with 6 x 19 or 6 x 37, IPS or XIP (EIP), RRL, FC or IWRC wire rope. Before using any National Swage fitting with any other type lay, construction or grade of wire rope, it is recommended that the termination be destructive tested and documented to prove the adequacy of the assembly to be manufactured.

S-506 COLD TUFF® Duplex Non-Tapered Sleeves

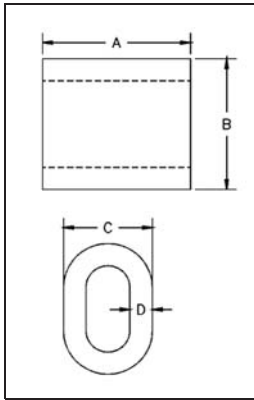

S-506 Steel Duplex Non-Tapered Sleeve Specifications									Press / Die Data	
S-506 Stock No.	Rope Size (mm)	Weight per 100 (kg)	Pkg. Qty.	Before Swage Dimensions				Max. After Swage Dimensions (mm)	Die Desc.	Stock No. 500 Ton 1000 Ton 1500 Ton 5 x 7
				A	B	C	D			
1039334	8	7.71	200	31.8	26.9	20.6	4.85	19.6	3/8 1st Stage	1192364
1039352	9-10	5.90	100	31.8	28.4	20.6	3.55	19.6	3/8 1st Stage	1192364
1039370	11	14.1	50	41.4	35.8	25.9	4.85	26.2	1/2 1st Stage	1192408
1039398	13	12.2	50	41.4	36.6	25.9	4.05	26.2	1/2 1st Stage	1192408
1039414	14	28.6	25	57.0	43.7	31.2	5.85	32.8	5/8 1st Stage	1192444
1039432	16	24.5	25	57.0	46.7	32.5	5.10	32.8	5/8 1st Stage	1192444
1039450	18-20	41.3	10	67.0	55.0	38.6	5.85	39.4	3/4 1st Stage	1192462
1039478	22	57	10	73.0	63.5	44.5	6.85	45.7	7/8 1st Stage	1192480
1039496	25-26	85	10	77.5	72.0	51.0	8.40	52.0	1 1st Stage	1192505
1039539	30-32	174	Bulk	103	89.0	63.5	9.65	65.0	1-3/8 socket	1193023

Shank Hooks for Swaging



SEE APPLICATION AND WARNING INFORMATION

Para Español: www.thecrosbygroup.com

On Pages 50 - 51

S-319SWG



- Wide range of sizes available:
 - Working Load Limit: 0.35 - 14 tonnes
 - Wire Rope sizes: 5 mm thru 30 mm.
- Swage shank hook terminations have an efficiency rating of 95% based on the catalog strength of wire rope.
- Quenched and Tempered. Heat treat process allows for ease of swaging.
- Forged Carbon Steel.
- Design Factor of 5 to 1.
- Black Oxide finish on body (Shank is uncoated).
- Utilizes standard Crosby 319N shank hooks with interlocking hook tip. Each hook has a pre-drilled cam which can be equipped with a latch.
- Utilizes standard National Swage swaging dies.
- All hooks incorporate Crosby's patented **QUIC-CHECK®** markings (Angle Indicators and Throat Deformation Indicators). See page 88 for detailed information.

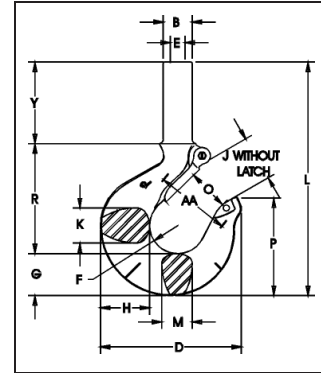

NOTE: For use with 6 X 19 or 6 X 37, IPS or XIP (EIP), XXIP (EEIP), RRL, FC, or IWRC wire rope.

Before using any Crosby fitting with any other type lay, construction or grade of wire rope, it is recommended that the termination be destructive tested and documented to prove the adequacy of the assembly to be manufactured. Refer to swage socket or swage button instructions in the National Swage Swaging Products and Procedures Brochure for proper swaging techniques.

S-319SWG

Shank Hooks for Swaging

Wire Rope Size (mm)	Hook ID Code	Working Load Limit (t)*	S-319SWG Stock No.	Weight Each (kg)	Required Swaging Die		Maximum After Swage Diameter (mm)
					Die Description	Die Stock No.	
5	DC	0.4	1053002	0.25	1/8" Button	1191621	10.2
6-7	FC	0.7	1053011	0.35	1/4" Socket	1192845	11.7
8	GC	1.1	1053020	0.57	1/4" Button	1191621	14.7
8	HC	1.1	1053039	0.83	3/8" Socket	1192863	18.0
9-10	HC	1.6	1053048	0.82	3/8" Socket	1192863	18.0
11	IC	2.1	1053057	1.65	1/2" Socket	1192881	23.1
12-13	IC	2.8	1053066	1.62	1/2" Socket	1192881	23.1
14-15	JC	3.5	1053075	3.34	5/8" Socket	1192907	29.5
16	JC	4.3	1053084	3.31	5/8" Socket	1192907	29.5
18	KC	6.2	1053093	5.77	3/4" Socket	1192925	36.1
20-22	LC	8.3	1053100	7.97	7/8" Socket	1192949	39.4
24-26	NC	11.0	1053119	14.3	1" Socket	1192961	45.7
28-30	OC **	14.0	1053128	24.4	1-1/8" Socket	1192989	52.1

* Minimum Ultimate Strength is 5 times the Working Load Limit.

** ID Code "O" is old 319 style hook.

Wire Rope Size (mm)	S-319SWG Stock No.	Dimensions (mm)														
		B	D	E	F	G	H	J	K	L	M	O	P	R	Y	AA
5	1053002	11.2	72.5	5.10	16.0	18.5	20.6	23.6	16.0	132	16.0	23.6	49.8	60.5	51.0	38.1
6-7	1053011	12.7	80.0	6.85	17.5	21.3	23.9	24.6	18.0	145	18.0	24.6	56.5	67.0	57.0	51.0
8	1053020	16.5	91.0	8.65	19.1	25.4	29.5	26.9	22.4	162	22.4	26.9	62.0	70.0	63.5	51.0
8	1053039	19.6	101	8.65	20.6	29.0	33.3	30.2	23.9	182	23.9	29.5	70.5	81.5	70.0	51.0
9-10	1053048	19.6	101	10.4	20.6	29.0	33.3	30.2	23.9	182	23.9	29.5	70.5	81.5	70.0	51.0
11	1053057	24.9	123	12.2	25.4	36.6	41.4	38.1	33.3	221	28.7	35.8	88.0	99.5	82.5	63.5
12-13	1053066	24.9	123	14.0	25.4	36.6	41.4	38.1	33.3	221	28.7	35.8	88.0	99.5	82.5	63.5
14-15	1053075	31.8	159	15.5	31.8	46.2	52.5	45.2	42.2	267	36.6	42.9	117	123	95.5	76.0
16	1053084	31.8	159	17.0	31.8	46.2	52.5	45.2	42.2	267	36.6	42.9	117	123	95.5	76.0
18	1053093	39.4	192	20.3	38.1	57.5	67.0	61.0	47.8	321	41.4	56.4	133	152	108	102
20-22	1053100	43.2	212	23.9	41.4	66.0	74.7	66.5	55.5	345	49.3	61.2	145	165	111	102
24-26	1053119	50.5	264	26.9	54.0	76.5	89.0	86.5	68.5	427	60.5	81.0	175	211	137	102
28-30	1053128	57.0	346	30.2	63.5	92.0	117	102	76.0	586	76.0	82.6	223	240	248	165

National Hydraulic Swaging Machines

National offers the highest quality and most complete line of Hydraulic Swaging Machines specifically designed to be used to swage fittings on wire rope.

3 Capacities to Fit your Requirements

500 Tons
1000 Tons
1500 Tons



SEE APPLICATION AND WARNING INFORMATION

Para Español: www.thecrosbygroup.com On Page 54 - 56



1500 Tonnes Hydraulic Swaging Machines
Approximate weight 15.6t. Overall height 2.6m.
Fast advance and retract speed.
Automatic slow, precision swaging speed.

The following features of National Hydraulic Swaging Machines offer a number of advantages for high production sling shops:

- A dual hydraulic system which combines the use of high speed and low pressure to bring dies into position; and the low speed and high pressure necessary for ideal swaging control.
 - Adjustable tonnage control, so tonnage can be set to match die block Working Load Limit.
 - Four column wide stance which provides the operator ample working clearance between columns and a large area for in-process sling storage.
 - Vertical swage action which gives an equalized press on the fitting to produce uniform high quality.
 - Self locating spring locks snap the shoe-type dies into place for quick set-up and change.
 - The National four column wide stance Hydraulic Swaging Machines, each equipped with an up-acting ram, have two side cylinders for fast approach and return of the main ram. They come in three swaging capacities.
- 500 ton (4450 kN)
 - 1000 ton (8900 kN)
 - 1500 ton (13350 kN)

Swaging Machine Capacity Chart for Swage Sleeves, Ferrules & Buttons

Hydraulic Swaging Machine Size	Swaging Method	Die Size (in.)	Largest Fitting Allowed to be Swaged (in.)			
			S-505 Sleeve	S-506 Sleeve	S-510 Ferrules	S-409 Buttons
500 Ton	Full Die	2-1/2 x 5 Mark Series 4 x 7 5 x 7	38	32*	14*	22*
1000 Ton	Full Die	4 x 7 5 x 7	64	32*	14*	32*
1500 Ton	Full Die	5 x 7 6 x 12	89	32*	14*	32*
3000 Ton	Full Die	6 x 12	114	32*	14*	32*

* Largest size fitting available.

Swaging Machine Capacity Chart for S-501 & S-502 Swage Sockets

Hydraulic Swaging Machine Size	Swaging Method	Die Size (in.)	Largest Fitting Allowed to be Swaged (mm)
500 Ton	Full Shank	2-1/2 x 5 Mark Series 4 x 7 5 x 7	19
	Progressive	4 x 7 5 x 7	32
1000 Ton	Full Shank	4 x 7 5 x 7	26
	Progressive	4 x 7 5 x 7	38
1500 Ton	Full Shank	5 x 7 6 x 12	32
	Progressive	5 x 7 6 x 12	52
3000 Ton	Full Shank	6 x 12	52
	Progressive	6 x 12	52

* Largest size fitting available.

NOTE: For special applications or conditions, contact Crosby National at (501) 982-3112.

WIRELOCK®

RESIN FOR SPELTER SOCKETS

Note: For use on 416, 417, 427 and 517 spelter sockets only.

- 100% termination efficiency.
- Temperature operating range is -65° F to +240° F.
- Ideal for on site applications.
- No hazardous molten metal.
- Improved fatigue life.
- Pouring temperature without booster pack is 48° F to 110° F.
- One booster pack if pouring temperature is 35° F to 48° F.
- Two booster packs if pouring temperature is 27° F to 35° F.
- Refer to WIRELOCK® Technical Manual for more information.
- Meets the performance requirements of EN13411-4: 2002



SEE APPLICATION AND WARNING INFORMATION
 Para Español: www.thecrosbygroup.com On Pages 52 - 53

Approvals

Lloyds Register of Shipping
 Det Norske Veritas (DNV)
 United States Coast Guard
 Registro Italiano Navale
 Germanischer Lloyd
 United States Navy
 American Bureau of Shipping.



U.S. Department of Transportation
 United States Coast Guard



WIRELOCK® W416-7 Socket Compound

W416-7 Kits				Booster Pack
Kit Size	Kit Per Case	Stock No.	Weight Each (kg)	Stock No.
100	20	1039602	.28	1039603
250	12	1039604	.57	1039605
500	12	1039606	1.15	1039607
1000	12	1039608	2.08	1039609
2000	12	1039610	4.08	1039611

Guide to amount WIRELOCK® Required

Wire Rope Size		WIRELOCK® Required (cc)	Wire Rope Size		WIRELOCK® (cc)
(mm)	(in.)		(mm)	(in.)	
6 - 7	1/4	9	44	1-3/4	700
8	5/16	17	48	1-7/8	700
9 - 10	3/8	17	51	2	1265
11	7/16	35	54	2-1/8	1265
13	1/2	35	56	2-1/4	1410
14	9/16	52	60	2-3/8	1410
16	5/8	52	64	2-1/2	1830
20	3/4	86	67	2-5/8	1830
22	7/8	125	70	2-3/4	2250
26	1	160	76	3	3160
28	1-1/8	210	82	3-1/4	3795
32	1-1/4	350	88	3-1/2	4920
36	1-3/8	350	94	3-3/4	5980
40	1-1/2	420	102	4	7730
42	1-5/8	495	—	—	—

NATO Numbers:

100cc 8030-21-902-1823
 250cc 8030-21-902-1824
 500cc 8030-21-902-1825
 1000cc 8030-21-902-1826

Witnessed and tested by American Bureau of Shipping. (ABS)

Approximate U.S. Measurements:

250cc's Kit 1 Cup
 500cc's Kit 1 Pint
 1000cc's Kit 1 Quart

The hazardous material/dangerous good classification under U.S. DOT, ICAO/IATA and IMO transportation regulations is Resin Solution, flammable liquid class 3, UN1866, packing group III. All shipments made by The Crosby Group, Inc. are under limited quantity packing provisions.

CROSBY CLIPS WARNINGS AND APPLICATION INSTRUCTIONS



WARNING

- Failure to read, understand, and follow these instructions may cause death or serious injury.
- Read and understand these instructions before using clips.
- Match the same size clip to the same size wire rope.
- Prepare wire rope end termination only as instructed.
- Do not use with plastic coated wire rope.
- Apply first load to test the assembly. This load should be of equal or greater weight than loads expected in use. Next, check and retighten nuts to recommended torque (See Table 1, this page).

Efficiency ratings for wire rope end terminations are based upon the catalog breaking strength of wire rope. The efficiency rating of a properly prepared loop or thimble – eye termination for clip sizes 1/8" through 7/8" is 80%, and for sizes 1" through 3-1/2" is 90%.

The number of clips shown (see Table 1) is based upon using RRL or RLL wire rope, 6 x 19 or 6 x 37 Class, FC or IWRC; IPS or XIP, XXIP. If Seale construction or similar large outer wire type construction in the 6 x 19 Class is to be used for sizes 1 inch and larger, add one additional clip. If a pulley (sheave) is used for turning back the wire rope, add one additional clip.

The number of clips shown also applies to rotation - resistant RRL wire rope, 8 x 19 Class, IPS, XIP, XXIP sizes 1-1/2 inch and smaller; and to rotation-resistant RRL wire rope, 19 x 7 Class, IPS, XIP, XXIP sizes 1-3/4 inch and smaller.

For other classes of wire rope not mentioned above, we recommend contacting Crosby Engineering at the address or telephone number on the back cover to ensure the desired efficiency rating.

For elevator, personnel hoist, and scaffold applications, refer to ANSI A17.1 and ANSI A10.4. These standards do not recommend U-Bolt style wire rope clip terminations. The style wire rope termination used for any application is the obligation of the user.

For OSHA (Construction) applications, see OSHA 1926.251.

1. Refer to Table 1 in following these instructions. Turn back specified amount of rope from thimble or loop. Apply first clip one base width from dead end of rope. Apply U-Bolt over dead end of wire rope – live end rests in saddle (Never saddle a dead horse!). Tighten nuts evenly, alternate from one nut to the other until reaching the recommended torque.



Figure 1

2. When two clips are required, apply the second clip as near the loop or thimble as possible. Tighten nuts evenly, alternating until reaching the recommended torque. When more than two clips are required, apply the second clip as near the loop or thimble as possible, turn nuts on second clip firmly, but do not tighten. Proceed to Step 3.



Figure 2

3. When three or more clips are required, space additional clips equally between first two - take up rope slack - tighten nuts on each U-Bolt evenly, alternating from one nut to the other until reaching recommended torque.



Figure 3

4. If a pulley (sheave) is used in place of a thimble, add one additional clip. Clip spacing should be as shown.

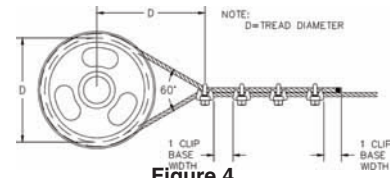

Figure 4

5. WIRE ROPE SPLICING PROCEDURES:

The preferred method of splicing two wire ropes together is to use inter-locking turnback eyes with thimbles using the recommended number of clips on each eye (See Figure 5).

An alternate method is to use twice the number of clips as used for a turnback termination. The rope ends are placed parallel to each other, overlapping by twice the turnback amount shown in the application instructions. The minimum number of clips should be installed on each dead end (See Figure 6). Spacing, installation torque, and other instructions still apply.



Figure 5

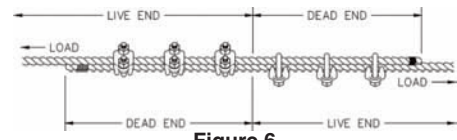

Figure 6

6. IMPORTANT

Apply first load to test the assembly. This load should be of equal or greater weight than loads expected in use. Next, check and retighten nuts to recommended torque. In accordance with good rigging and maintenance practices, the wire rope end termination should be inspected periodically for wear, abuse, and general adequacy.

Clip Size (in.)	Rope Size (mm)	Minimum No. of Clips	Amount of Rope to Turn Back in mm	* Torque in Nm
1/8	3-4	2	85	6.1
3/16	5	2	95	10.2
1/4	6-7	2	120	20.3
5/16	8	2	133	40.7
3/8	9-10	2	165	61.0
7/16	11-12	2	178	88
1/2	13	3	292	88
9/16	14-15	3	305	129
5/8	16	3	305	129
3/4	18-20	4	460	176
7/8	22	4	480	305
1	24-25	5	660	305
1-1/8	28-30	6	860	305
1-1/4	33-34	7	1120	488
1-3/8	36	7	1120	488
1-1/2	38-40	8	1370	488
1-5/8	41-42	8	1470	583
1-3/4	44-46	8	1550	800
2	48-52	8	1800	1017
2-1/4	56-58	8	1850	1017
2-1/2	62-65	9	2130	1017
2-3/4	68-72	10	2540	1017
3	75-78	10	2690	1627
3-1/2	85-90	12	3780	1627

If a pulley (sheave) is used for turning back the wire rope, add one additional clip. See Figure 4.

If a greater number of clips are used than shown in the table, the amount of turnback should be increased proportionately.

*The tightening torque values shown are based upon the threads being clean, dry, and free of lubrication.

CROSBY FIST GRIP CLIPS

WARNINGS AND APPLICATION INSTRUCTIONS



New Style Fist Grip®
3/16" - 5/8"



Fist Grip® Clips
3/4" - 1-1/2"

WARNING

- Failure to read, understand, and follow these instructions may cause death or serious injury.
- Read and understand these instructions before using clips.
- Match the same size clip to the same size wire rope.
- Do not mismatch Crosby clips with other manufacturers clips.
- Prepare wire rope end termination only as instructed
- Do not use plastic coated wire rope.
- Apply first load to test the assembly. This load should be of equal or greater weight than loads expected in use. Next, check and retighten nuts to recommended torque (See Table 1, this page).

Efficiency ratings for wire rope end terminations are based upon the catalog breaking strength of wire rope. The efficiency rating of a properly prepared loop or thimble-eye termination for clip sizes 1/8" through 7/8" is 80%, and for sizes 1" through 3- 1/2" is 90%.

The number of clips shown (see Table 1) is based upon using RRL or RLL wire rope, 6 x 19 or 6 x 37 Class, FC or IWRC; IPS or XIP, XXIP. If Seale construction or similar large outer wire type construction in the 6 x 19 Class is to be used for sizes 1 inch and larger, add one additional clip. If a pulley (sheave) is used for turning back the wire rope, add one additional clip.

The number of clips shown also applies to rotation - resistant RRL wire rope, 8 x 19 Class, IPS, XIP, XXIP sizes 1-1/2 inch and smaller; and to rotation-resistant RRL wire rope, 19 x 7 Class, IPS, XIP, XXIP sizes 1-1/2 inch and smaller.

For other classes of wire rope not mentioned above, we recommend contacting Crosby Engineering at the address or telephone number on the back cover to ensure the desired efficiency rating.

The style of wire rope termination used for any application is the obligation of the user.

For OSHA (Construction) applications, see OSHA 1926.251

1. Refer to Table 1 in following these instructions. Turn back specified amount of rope from thimble or loop. Apply first clip one base width from dead end of rope. Tighten nuts evenly, alternating from one nut to the other until reaching the recommended torque.



Figure 1

2. When two clips are required, apply the second clip as near the loop or thimble as possible. Tighten nuts evenly, alternating until reaching the recommended torque. When more than two clips are required, apply the second clip as near the loop or thimble



Figure 1

as possible, turn nuts on second clip firmly, but do not tighten. Proceed to Step 3.

3. When three or more clips are required, space additional clips equally between first two - take up rope slack - tighten nuts on each Clip evenly, alternating from one nut to the other until reaching recommended torque.



Figure 3

4. If a pulley (sheave) is used in place of a thimble, add one additional Fist Grip. Fist Grip spacing should be as shown.

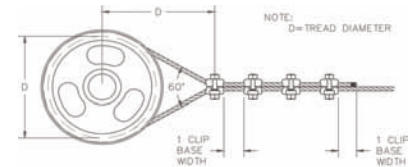

Figure 4

5. WIRE ROPE SPlicing PROCEDURES:

The preferred method of splicing two wire ropes together is to use interlocking turnback eyes with thimbles, using the recommended number of clips on each eye (See Figure 5).

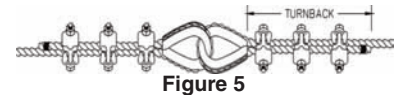

Figure 5

An alternate method is to use twice the number of clips as used for a turnback termination. The rope ends are placed parallel to each other, overlapping by twice the turnback amount shown in the application instructions. The minimum number of clips should be installed on each dead end (See Figure 6). Spacing, installation torque, and other instructions still apply.

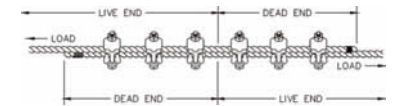

Figure 6

6. IMPORTANT

Apply first load to test the assembly. This load should be of equal or greater weight than loads expected in use. Next, check and retighten nuts to recommended torque.

In accordance with good rigging and maintenance practices, the wire rope end termination should be inspected periodically for wear, abuse, and general adequacy.

Table 1

Clip Size (in.)	Rope Size (mm)	Minimum No. of Clips	Amount of Rope to Turn Back in mm	* Torque in Nm.
3/16	5	2	100	40.7
1/4	6-7	2	100	40.7
5/16	8	2	127	40.7
3/8	9-10	2	133	61.0
7/16	11-12	2	165	88.1
1/2	13	3	279	88.1
9/16	14-15	3	323	176
5/8	16	3	342	176
3/4	18-20	3	406	305
7/8	22	4	660	305
1	24-25	5	940	305
1-1/8	28-30	5	1040	488
1-1/4	32-34	6	1400	488
1-3/8	36	6	1570	678
1-1/2	38-40	7	1980	678

If a pulley (sheave) is used for turning back the wire rope, add one additional clip. See Figure 4.

If a greater number of clips are used than show in the table, the amount of turn-back should be increased proportionately.

* The tightening torque values shown are based upon the threads being clean, dry, and free of lubrication.

WEDGE SOCKET WARNING AND APPLICATION INSTRUCTIONS

Extended Wedge Socket Assembly
U.S. Patent No. 5,553,360

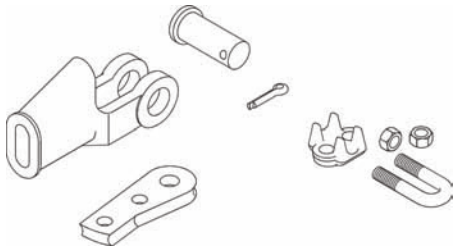

S-421T / US-422T "TERMINATOR™"

NOTE: Existing Crosby S-421 Wedge Sockets can be retrofitted with the New Terminator Wedge. Existing US-422 Wedge Sockets can be retrofitted with terminator wedges.

See the Crosby Catalog for additional information.



New **QUIC-CHECK®** "Go" and "No-Go" features cast into wedge. The proper size wire rope is determined when the following criteria are met:
1. The wire rope shall pass thru the "Go" hole in the wedge.
2. The wire rope shall NOT pass thru the "No-Go" hole in the wedge.

Important Safety Information - Read and Follow Inspection/Maintenance Safety

- Always inspect socket, wedge and pin before using.
- Do not use part showing cracks.
- Do not use modified or substitute parts.
- Repair minor nicks or gouges to socket or pin by lightly grinding until surfaces are smooth. Do not reduce original dimension more than 10%. Do not repair by welding.
- Inspect permanent assemblies annually, or more often in severe operating conditions.
- Do not mix and match wedges or pins between models or sizes.
- Always select the proper wedge and socket for the wire rope size.

Assembly Safety

- Use only with standard 6 to 8 strand wire rope of designated size. For intermediate size rope, use next larger size socket. For example: When using 9/16" diameter wire rope use a 5/8" size Wedge Socket Assembly. Welding of the tail on standard wire rope is not recommended. The tail length of the dead end should be a minimum of 6 rope diameters but not less than 6" (See Figure 1).
- To use with Rotation Resistant wire rope (special wire rope constructions with 8 or more outer strands) ensure that the dead end is welded, brazed or seized before inserting the wire rope into the wedge socket to prevent core slippage or loss of rope lay. The tail length of the dead end should be a minimum of 20 rope diameters but not less than 6" (See Figure 1).
- Properly match socket, wedge and clip (See Table 1) to wire rope size.
- Align live end of rope, with center line of pin (See Figure 1).
- Secure dead end section of rope (See Figure 1).
- Tighten nuts on clip to recommended torque (See Table 1).
- Do not attach dead end to live end or install wedge backwards (See Figure 2).
- **Use a hammer to seat Wedge and Rope as deep into socket as possible before applying first load.**

WARNING

- Loads may slip or fall if the Wedge Socket is not properly installed.
- A falling load can seriously injure or kill.
- Read and understand these instructions before installing the Wedge Socket.
- Do not side load the Wedge Socket.
- Apply first load to fully seat the Wedge and Wire Rope in the socket. This load should be of equal or greater weight than loads expected in use.
- Do not interchange wedges between S-421T and US422T or between sizes.

Figure 1

Tail Length	
Standard 6 to 8 strand wire rope	Rotation Resistant Wire Rope
A minimum of 6 rope diameter, but not less than 150mm.	A minimum of 20 rope diameters, but not less than 150mm.

Rope Size	9-10	11-13	14-16	18-19	20-22	24-26	28	32
Clip Size	3/8	1/2	5/8	3/4	7/8	1	1-1/8	1-1/4
* Torque Nm	61	88	129	176	305	305	305	488

* The tightening torque values shown are based upon the threads being clean, dry, and free of lubrication.

Figure 2

Operating Safety

- Apply first load to fully seat the Wedge and Wire Rope in the socket. This load should be of equal or greater weight than loads expected in use.
- Efficiency rating of the Wedge Socket termination is based upon the catalog breaking strength of Wire Rope. The efficiency of a properly assembled Wedge Socket is 80%.
- During use, do not strike the dead end section with any other elements of the rigging (Called two blocking).

WEDGE SOCKET WARNING AND APPLICATION INSTRUCTIONS

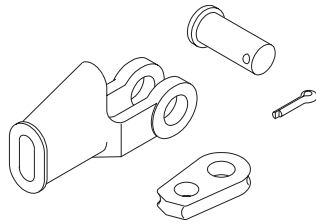

S-421
US-422

Important Safety Information - Read and Follow

Inspection/Maintenance Safety

- Always inspect socket, wedge and pin before using.
- Do not use part showing cracks.
- Do not use modified or substitute parts.
- Repair minor nicks or gouges to socket or pin by lightly grinding until surfaces are smooth. Do not reduce original dimension more than 10%. Do not repair by welding.
- Inspect permanent assemblies annually, or more often in severe operating conditions.
- Do not mix and match wedges or pins between models or sizes.
- Always select the wedge and socket for the wire rope size.

Assembly Safety

- Use only with standard 6 to 8 strand wire rope of designated size. For intermediate size rope, use next larger size socket. For example: When using 14mm diameter wire rope use a 16mm size Wedge Socket Assembly. Welding of the tail on standard wire rope is not recommended. The tail length of the dead end should be a minimum of 6 rope diameters but not less than 150mm.
- Align live end of rope, with center line of pin. (See Figure 1)
- Secure dead end section of rope. (See Figure 1)
- **DO NOT ATTACH DEAD END TO LIVE END.** (See Figure 2)
- Use a hammer to seat Wedge and Rope as deep into socket as possible before applying first load.
- **To use with Rotation Resistant wire rope** (special wire rope constructions with 8 or more outer strands) ensure that the dead end is welded, brazed or seized before inserting the wire rope into the wedge socket to prevent core slippage or loss of rope lay. The tail length of the dead end should be a minimum of 20 rope diameters but not less than 150mm (Figure 1).

⚠ WARNING

- Loads may slip or fall if the Wedge Socket is not properly installed
- A falling load can seriously injure or kill.
- Read and understand these instructions before installing the Wedge Socket.
- Do not side load the Wedge Socket.
- Do not interchange Crosby wedge socket, wedge or pin with non Crosby wedge socket, wedge or pin.
- Apply first load to fully seat the Wedge and Wire Rope in the socket. This load should be of equal or greater weight than loads expected in use.
- Do not interchange wedges between S-421 and US-422 or between sizes.

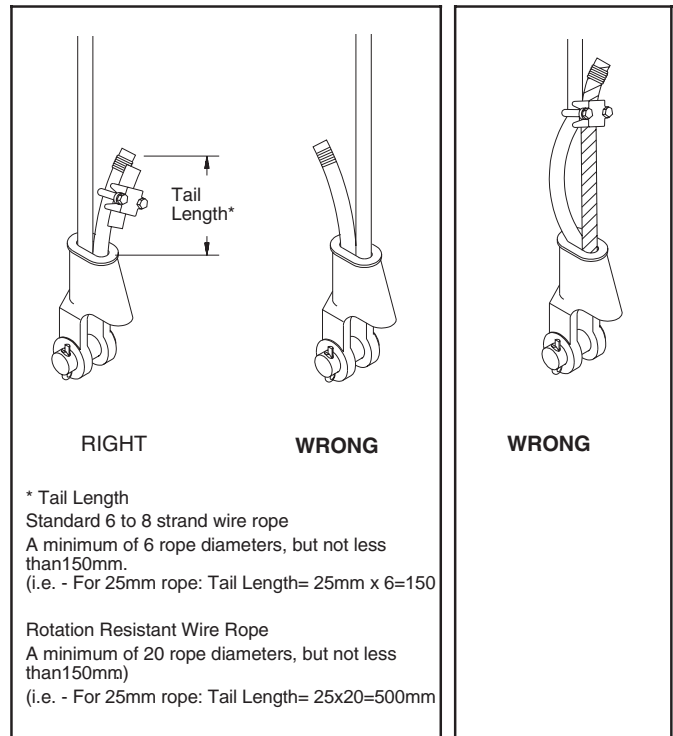

Figure 1

Figure 2

* Tail Length
Standard 6 to 8 strand wire rope
A minimum of 6 rope diameters, but not less than 150mm.
(i.e. - For 25mm rope: Tail Length= 25mm x 6=150)

Rotation Resistant Wire Rope
A minimum of 20 rope diameters, but not less than 150mm)
(i.e. - For 25mm rope: Tail Length= 25x20=500mm)

Operating Safety

- Apply first load to fully seat the Wedge and Wire Rope in the socket. This load should be of equal or greater weight than loads expected in use.
- Efficiency rating of the Wedge Socket termination is based upon the catalog breaking strength of Wire Rope. The efficiency of properly assembled Wedge Socket is 80%.
- During use, do not strike the dead end section with any other elements of the rigging (Called two-blocking).

CROSBY® SHANK HOOKS FOR SWAGING

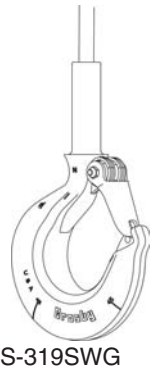

WARNING AND APPLICATION INSTRUCTIONS

- S-319SWG hooks are recommended for use with 6 x 19 or 6 x 37, IPS or XIP (EIP), XXIP (EEIP), RRL, FC or IWRC wire rope. Before using any National Swage fitting with any other type lay, construction or grade of wire rope, it is recommended that the termination be destructively tested and documented to prove the adequacy of the assembly to be manufactured.
- Use only Crosby shank hooks designed exclusively for swaging.
- A visual periodic inspection for cracks, nicks, wear gouges and deformation as part of a comprehensive documented inspection program, should be conducted by trained personnel in compliance with the schedule in ANSI B30. 10.
- For hooks used in frequent load cycles or pulsating loads, the hook should be periodically inspected by Magnetic Particle or Dye Penetrant.
- Never use a hook whose throat opening has been increased, or whose tip has been bent more than 10 degrees out of plane from the hook body, or is in any other way distorted or bent.
- Note: A latch will not work properly on a hook with a bent or worn tip.
- Never use a hook that is worn beyond the limits shown in Figure 1.
- Remove from service any hook with a crack, nick, or gouge. Hooks with a crack, nick, or gouge shall be repaired by grinding lengthwise, following the contour of the hook, provided that the reduced dimension is within the limits shown in Figure 1.

⚠ WARNING

- Loads may disengage from hook if proper procedures are not followed.
- A falling load may cause serious injury or death.
- See OSHA Rule 1926.550(g) for personnel hoisting by cranes or derricks. A Crosby 319 hook with a PL Latch attached (when secured with bolt, nut and pin) may be used for lifting personnel. A Crosby S-319N hook with an S-4320 Latch attached (when secured with cotter pin or bolt, nut and pin) may be used for lifting personnel.
- Hook must always support the load. The load must never be supported by the latch.
- Never exceed the Working Load Limit (WLL) of the wire rope and hook system.
- Read and understand “National Swage Swaging Products and Procedures” manual before swaging the hook.

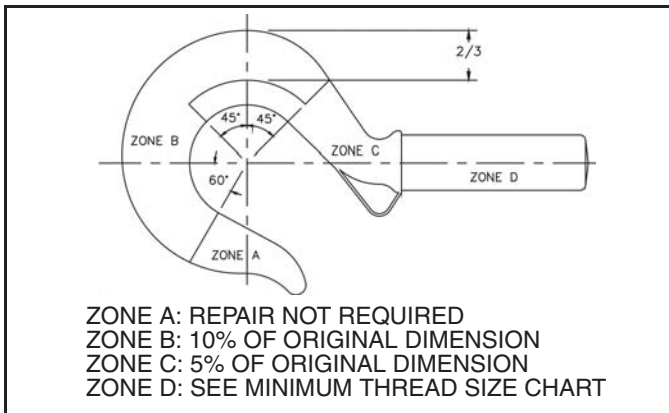

FIGURE 1

- Never repair, alter, rework, or reshape a hook by welding, heating, burning, or bending.
- Never side load, back load, or tip load a hook (See Figure 2).
- The use of a latch may be mandatory by regulations or safety codes; e.g., OSHA, MSHA, ANSI/ASME B30, insurance, etc.. (Note: When using latches, see instructions in Understanding: The Crosby Group Product Warnings for further information.)
- Always make sure the hook supports the load. (See Figure 3). The latch must never support the load (See Figure 4).
- When placing two (2) sling legs in hook, make sure the angle from the vertical to the outermost leg is not greater than 45 degrees, and the included angle between the legs does not exceed 90 degrees* (See Figure 5).

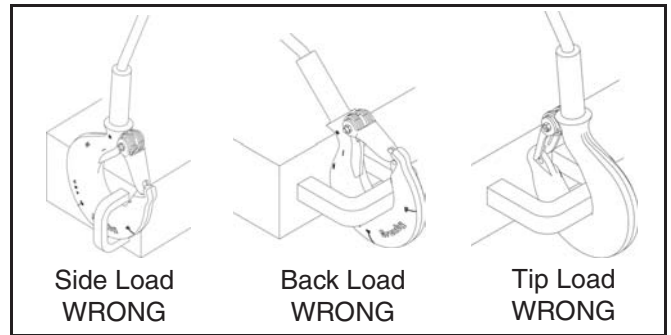

Figure 2

* For angles greater than 90 degrees, or more than two (2) legs, a master link or bolt type anchor shackle should be used to attach the legs of the sling to the hook.

- See ANSI/ASME B30.10 “Hooks” for additional information.
- In accordance with ANSI B30.9, all slings terminated by swaging shall be proof tested.
- S-319SWG hooks are designed to be a component of a system, and therefore rated based on the working limit of the system of which they are attached.
- The frame code on each S-319SWG hook is to facilitate proper latch selection only, and has no reference to the working load limit of the hook.

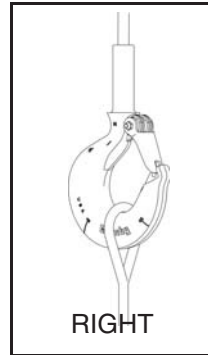

Figure 3

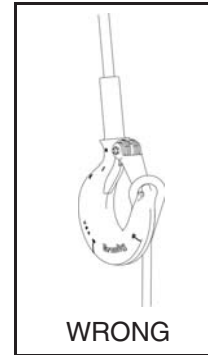

Figure 4

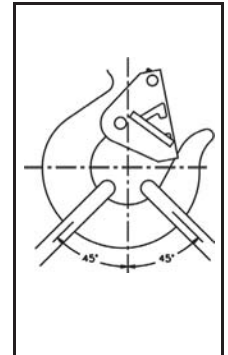

Figure 5

Wire Rope Size		Hook Frame I.D. Code	Required Swaging Die		Maximum After Swage Dimensions	
(in.)	(mm)		Stock No.	Description	(in.)	(mm)
3/16	4.75	DC	1191621	1/8" Swage Button Die	0.40	10.2
1/4	6.35	FC	1192845	1/4" Swage Button Die	0.46	11.7
5/16	7.95	GC	1191621	1/4" Swage Button Die	0.46	11.7
5/16	7.95	HC	1192863	3/8" Swage Button Die	0.71	18.0
3/8	9.55	HC	1192863	3/8" Swage Button Die	0.71	18.0
7/16	11.1	IC	1192881	1/2" Swage Button Die	0.91	23.1
1/2	12.7	IC	1192881	1/2" Swage Button Die	0.91	23.1
9/16	14.3	JC	1192907	5/8" Swage Button Die	1.16	29.5
5/8	15.9	JC	1192907	5/8" Swage Button Die	1.16	29.5
3/4	19.1	KC	1192925	3/4" Swage Button Die	1.42	36.1
7/8	22.2	LC	1192949	7/8" Swage Button Die	1.55	39.4
1	25.4	NC	1192961	1" Swage Button Die	1.80	45.7
1-1/8	28.6	OC**	1192989	1-1/8" Swage Button Die	2.05	52.1

** S319C Style Hook

WIRELOCK® WARNINGS AND APPLICATION INSTRUCTIONS

⚠ WARNING

- Incorrect use of WIRELOCK® can result in an unsafe termination which may lead to serious injury, death, or property damage.
- Do not use WIRELOCK® with stainless steel rope in salt water environment applications.
- Use only soft annealed iron wire for seizing.
- Do not use any other wire (copper, brass, stainless, etc.) for seizing.
- Never use an assembly until the WIRELOCK® has gelled and cured.
- Remove any non-metallic coating from the broomed area.
- Sockets with large grooves need to have those grooves filled before use with WIRELOCK®.
- Read, understand, and follow these instructions and those on product containers before using WIRELOCK®.

The following simplified, step-by-step instructions should be used only as a guide for experienced users. For full information, consult our document **WIRELOCK® TECHNICAL DATA MANUAL, WIRE ROPE USER MANUAL** by **AISI** and **WIRE ROPE MANUFACTURERS CATALOGS**.

STEP 1 - SOCKET SELECTION

1. **WIRELOCK®** is recommended for use with Crosby 416 - 417 Spelter Sockets.
2. For use with sockets other than Crosby 416 - 417 consult the socket manufacturer or Crosby Engineering.
3. Sockets used with **WIRELOCK®** shall comply with Federal or International (CEN, ISO) Standards.
4. **WIRELOCK®**, as with all socketing media, depends upon the wedging action of the cone within the socket basket to develop full efficiency. A rough finish inside the socket may increase the load at which seating will occur. Seating is required to develop the wedging action.

STEP 2 - SEIZING

Seize the wire rope or strand as shown using soft annealed iron wire.

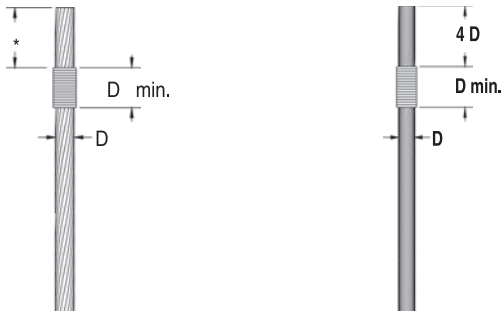

* = 5D or 50d (d = Diameter of the largest wire)
WHICHEVER IS GREATER

Strand

Wire Rope

STEP 3 - BROOMING

1. Unlay the strands of the wire rope and IWRC as far as the seizing.
2. Cut out any fiber core.
3. Unlay the individual wires from each strand, including the IWRC, completely, down to the seizing.
4. Remove any plastic material from broomed area.

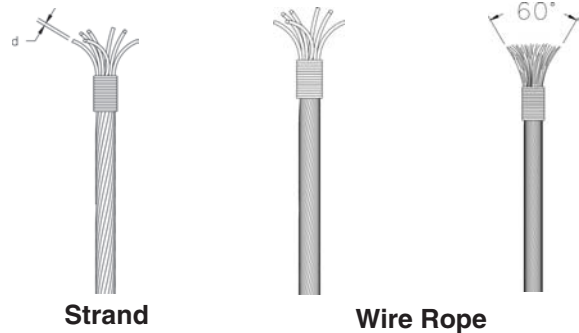

Strand

Wire Rope

STEP 4 - CLEANING

1. The method of cleaning will depend on the lubricant and/ or coating on the wire.
2. The methods and materials used for cleaning should comply with the current EPA regulations.
3. Consult the Wire Rope Technical Board, your Wire Rope supplier or the Wire Rope Manufacturer for recommended materials and methods.
4. The currently recommended Trichlorethane does not comply with the "Clean Air Act of 1990, Section 611, Ozone Depletion Substances."

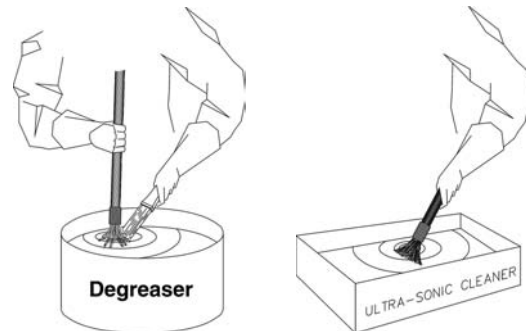

STEP 5 - POSITIONING OF SOCKET

1. Position socket over the broom until the wires are **LEVEL** with the top of the socket basket or to a minimum embedded length as shown.
2. Clamp rope and socket vertically ensuring alignment of their axes.
3. **CAUTION: DO NOT USE OVERSIZED SOCKETS FOR WIRE ROPE.**



Wire Rope

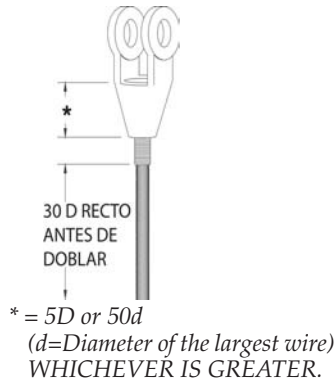

Strand

STEP 6 - SEAL SOCKET

Seal the base of the socket with putty or plasticine to prevent leakage of the **WIRELOCK®**.



STEP 7 - WIRELOCK® KITS

1. **WIRELOCK®** kits are pre-measured and consist of two (2) containers - one (1) with resin and one (1) with granular compound.
2. Use the complete kit - **NEVER MIX LESS THAN THE TOTAL CONTENTS OF BOTH CONTAINERS.**
3. Each kit has a shelf life clearly marked on each container and this must be observed. **NEVER USE OUT OF DATE KITS.**



CAUTION

- **WIRELOCK®** resin, in liquid state, is flammable.
- Chemicals used in this product can give off toxic fumes and can burn eyes and skin.
- Never use out-of-date material.
- Use only in well-ventilated work areas.
- Never breathe fumes directly or for extended time.
- Always wear safety glasses to protect eyes.
- Always wear gloves to protect hands.
- Avoid direct contact with skin anywhere.

STEP 8 - MIXING AND POURING

1. Mix and pour **WIRELOCK®** within the temperature range of 9 degrees to 43 degrees C. Booster kits are available for reduced temperatures.
2. Pour all the resin into a container containing all the granular compound and mix thoroughly for two (2) minutes with a flat paddle.
3. Immediately after mixing, slowly pour the mixture down one side of the socket until the socket basket is full.

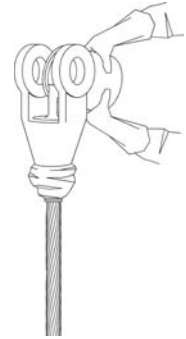

STEP 9 - CURING

1. **WIRELOCK®** will gel in approximately 15 minutes, in a temperature range 18 degrees C to 24 degrees C.
2. The socket must remain in the vertical position for an additional ten (10) minutes after gel is complete.
3. The socket will be ready for service 60 minutes after gelling.
4. Never heat sockets to accelerate gel or curing.



STEP 10 - RE-LUBRICATION

Re-lubricate wire rope as required.

STEP 11 - PROOF LOADING

Whenever possible, the assembly should be proof loaded. All slings with poured sockets, in accordance with ASME B30.9, shall be Proof Loaded.

IMPORTANT SAFETY INFORMATION

National Four Post Swaging Machine



Operation Safety

- NEVER use dies that are cracked, worn or abraded (galled).
- NEVER use dies that have an oversized cavity.
- ALWAYS use a matched set of dies.
- When swaging steel fittings, DO NOT SHIM DIES. Dies for steel fittings must be free to float and align one to the other.
- When swaging aluminum fittings, THE STEEL DIES MUST BE SHIMMED. Shim the side of the die to ensure the proper cavity alignment for flash removal.
- NEVER shim between the dies.
- When Swaging Crosby National fittings, use only the proper capacity swaging machine for the size of fitting used (See Swaging Capacity Chart). If the swaging machine capacity exceeds the die block Working Load Limit rating, adjust the swaging machine tonnage to the Working Load Limit shown on the die block being used. See Table 1 for die block Working Load Limit.
- Always use the correct size and type of die for the size wire rope fitting used.
- Always lubricate die faces and cavities with light weight oil.
- Progressive swaging of fittings must be done in accordance with procedure shown in “Swaging Products and Procedures” booklet. Only open channel dies are to be used.
- Stop swaging when the cavity side of both dies touch.
- Make sure part is swaged to the recommended after swage dimensions (See Crosby General Catalog or National Swage Brochure, Die Guide, or Die Chart).
- If a swage fitting other than a Crosby National is used, determine adequacy of the termination by a destructive pull test.
- All swage sockets must be swaged with socket head adjacent to the socket relief (largest radius) on the die.
- For special applications or conditions, contact Crosby National.



WARNING

- Misuse of swaging machine can result in serious injury or death.
- READ, UNDERSTAND, AND FOLLOW all the information in this warning document and the instructions shown in “Swaging Products and Procedures” booklet before operating the swaging machine.
- Swaging machine operators must be trained in accordance with the information supplied by The Crosby Group, Inc. The swaging machine owner is responsible for the training and the safe operation of the swaging machine.
- Do not swage oversize parts.
- Only swage parts of the proper design, material and hardness.
- If misused, dies and/or die holders may break. **PROTECT YOURSELF AND OTHERS: Always stay away from the sides of the swaging machine during swaging operations and alert others in your work area.**
- Keep head, hands, and body away from moving swaging machine and die parts.
- Consult die manufacturer for correct use of their product.
- Adjust swaging machine tonnage to the Working Load Limit (WLL) tonnage shown on the die block being used. If the Working Load Limit is not legible, refer to Die height & width and corresponding Working Load Limit (See Table 1). Failure to do so can result in serious injury or death.

TABLE 1

Die Size (Height x Width)	Working Load Limit (WLL)*
2" x 3-1/2"	200 Ton Mark Series
2-1/2" x 4"	200 Ton National
2-1/2" x 5"	500 Ton Mark Series
4" x 7"	1,200 Ton Mark Series
5" x 7"	1,500 Ton National
6" x 12"	3,000 Ton National

* Note: These Working Load Limits are for Crosby® National Die Blocks only. The Working Load Limits of die blocks from other manufacturers may vary.

Inspection Maintenance Safety

- Make sure all bolts and nuts are in place and tightened to recommended torque as shown in Table A, on page 56.
- Load block or die base plate surfaces must be to manufacturers specifications for thickness and flatness to provide complete support of the die during swaging.
- Make sure die holder side rails are not bent or loose.
- Clean dies and die holder surfaces. Keep free of metal shavings, slag, grit, sand, floor dry, etc.
- Lubricate the four guide bushings daily with light oil.
- Inspect the rods for corrosion. Use #000 emery cloth or steel wool to maintain a high polish surface.
- Do not increase the hydraulic system pressure above the factory preset pressure of: 6500 psi for 500 ton, 1000 ton and 1500 ton swaging machines - 5000 psi for 3000 ton swaging machine.
- Under ordinary operating conditions, drain and clean reservoir every two (2) years.
- Filters inside of the reservoir should be cleaned every time the reservoir is drained and cleaned. The Racine “tell-tale” suction filter should be cleaned every six (6) months.

Die Working Load Limit Pressure Adjustment on Lower Cylinder National 500 Ton through 1500 Ton Swaging Machines

Follow this procedure to adjust swaging tonnage (pressure) on your swaging machine.

1. Install the die holder(s) or die adapter with the dies to be used.
2. Bring the dies together (without a part in the dies) until they just touch.
3. Turn the tonnage control valve, which is located on the control panel left of the tonnage gauge, counter-clockwise about (6) six turns or until knob no longer turns.
4. Now (without a part in the dies) apply pressure to the dies by pressing the foot pedal marked “up”.
 - A. If the tonnage is lower than desired Working Load Limit, turn the valve clockwise while continuing to press the foot pedal marked “up” until desired Working Load Limit is reached.
 - B. If tonnage is higher than desired Working Load Limit, release pressure by pressing the pedal marked “down”. Then repeat steps 2 through 4.

Die Working Load Limit Pressure Adjustment on 3000 Ton Swaging Machine

For reducing tonnage, use selector switch on front of control panel to select lower tonnage (approximately 1500 Tons) or 3000 Ton.



WARNING

ALWAYS USE 5 X 7 OR 6 X 12 DIES AT 1500 TON SETTING.



WARNING

USE ONLY 6 X 12 DIES ON TONNAGE THAT EXCEEDS 1500 TONS.

Swaging Machine Capacity Chart for Swage Sleeves, Ferrules & Buttons

Hydraulic Swaging Machine Size	Swaging Method	Die Size (in.)	Largest Fitting Allowed to be Swaged (mm) *			
			S-505 Sleeve	S-506 Sleeve	S-510 Ferrules	S-409 Buttons
500 Ton	Full Die	Mark Series 2-1/2 x 5 4 x 5 5 x 7	38	32*	14*	22*
1000 Ton	Full Die	4 x 7 5 x 7	64	32*	14*	32*
1500 Ton	Full Die	5 x 7 6 x 12	89	32*	14*	32*
3000 Ton	Full Die	6 x 12	114*	32*	14*	32*

* Largest size fitting available.

Swaging Machine Capacity Chart for S-501 & S-502 Swage Socket

Hydraulic Swaging Machine Size	Swaging Method	Die Size (in.)	Largest Fitting Allowed to be Swaged (mm) *
500 Tons	Full Shank	Mark Series 2-1/2 x 5 4 x 7 5 x 7	19
	Progressive	4 x 7 5 x 7	32
1000 Tons	Full Shank	4 x 7 5 x 7	26
	Progressive	4 x 7	38
1500 Tons	Full Shank	5 x 7 6 x 12	32
	Progressive	5 x 7 6 x 12	52
3000 Tons	Full Shank	6 x 12	52
	Progressive	6 x 12	52*

* Largest size fitting available.

NATIONAL HYDRAULIC SWAGING MACHINE TORQUE MAINTENANCE INFORMATION

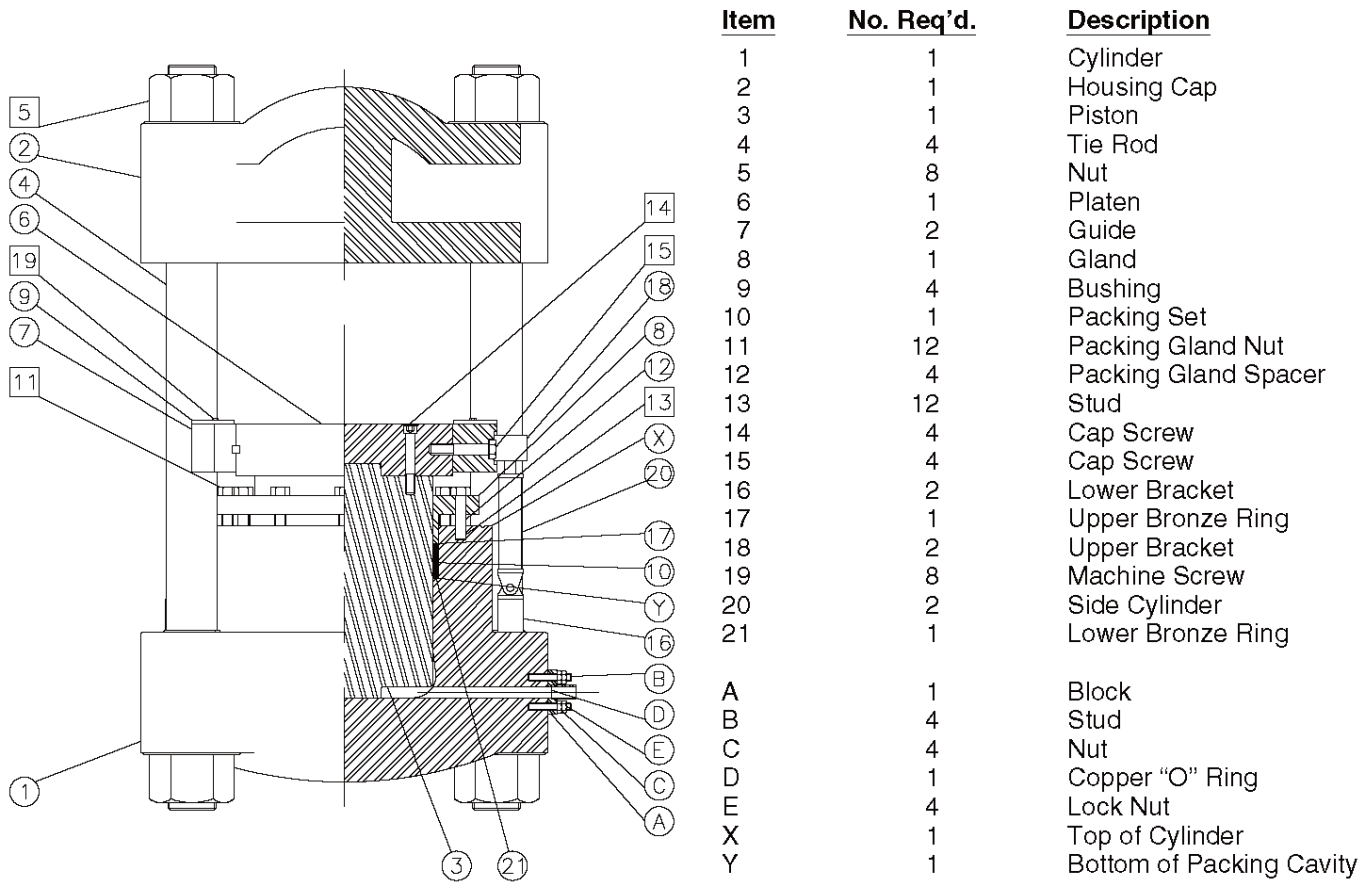
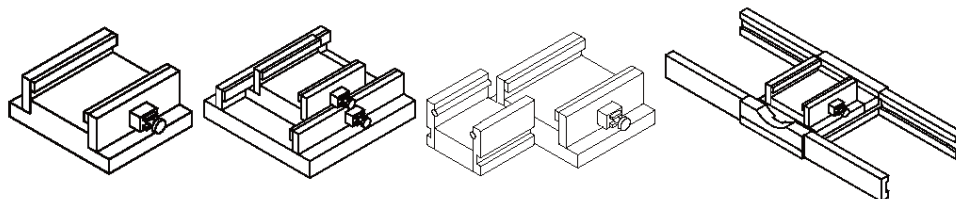

Table A						
Item #	Description	Torque in Nm				Maintenance Schedule
		500 Ton Swaging Machine	800 Ton Swaging Machine	1000 Ton Swaging Machine	1500 Ton Swaging Machine	
5	Tie Rod Nuts	2712	3051	3390	3390	Weekly
14	Piston Bolts	712	814	814	950	Monthly
11	Packing Gland Nuts (over spacers only) "all others hand tighten"	270	270	270	270	Weekly
15	Platen Guide Bolts	240	340	340	340	Weekly
13	Packing Gland Bolts Side Cylinder Bolts	950 136	1085 N/A	1085 136	1085 200	6 Months Weekly
19	Guide Bushing Bolts	20	20	20	20	Weekly
80 M Piston Pump Pistons		130 to 170 all swaging machines				



Torque in ft. / lbs.		
Die Holder	1/4 - 20 UNC	13
Bolt Torque	5/16 - 18 UNC	15
	5/8 - 11UNC	211
	7/8 - 9 UNC	583