

DILLON

EDxtreme Dynamometer Specifications

Model	Capacity x Resolution (normal/enhanced)			Body Construction and Overload Design
EDx-1T (EDx-2.5K)	2,500 lbf x 2/0.5	1,000 kgf x 1/0.2	10,000 N x 10/2	Aircraft quality 2024 Aluminum 700% Ultimate overload protection
EDx-2T (EDx-5K)	5,000 lbf x 5/1	2,000 kgf x 2/0.5	20,000 N x 20/5	
EDx-5T (EDx-10K)	10,000 lbf x 10/2	5,000 kgf x 5/1	50,000 N x 50/10	
EDx-10T (EDx-25K)	25,000 lbf x 20/5	10,000 kgf x 10/2	100,000 N x 100/20	Aircraft quality E4340 Alloy Steel 500% Ultimate overload protection
EDx-20T (EDx-50K)	50,000 lbf x 50/10	20,000 kgf x 20/5	200,000 N x 200/50	
EDx-50T (EDx-100K)	100,000 lbf x 100/20	50,000 kgf x 50/10	500,000 N x 500/100	
EDx-75T (EDx-160K)	160,000 lbf x 100/50	75,000 kgf x 50/20	-----	Aircraft quality E4340 Alloy Steel 400% Ultimate overload protection
EDx-100T (EDx-220K)	220,000 lbf x 200/50	100,000 kgf x 100/20	-----	
EDx-150T (EDx-330K)	330,000 lbf x 200/100	150,000 kgf x 100/50	-----	
EDx-250T (EDx-550K)	550,000 lbf x 500/200	250,000 kgf x 200/50	-----	

Note: Model in parenthesis shows U.S. convention for describing capacities.

Dimensions <i>Dimensions shown are nominal and subject to tolerances</i>										
Model		A	B	C	D	E	F	G	H	J
EDx-1T	inch mm	10.6 269	5.0 127	7.8 198	1.06 26	0.75 19	15.3 389	13.4 340	1.36 34	1.69 43
EDx-2T	inch mm	10.6 269	5.0 127	7.8 198	1.06 26	0.75 19	15.3 389	13.4 340	1.36 34	1.69 43
EDx-5T	inch mm	11.4 289	5.3 135	8.1 206	1.38 35	1.00 25	17.8 451	15.8 402	2.17 56	2.28 58
EDx-10T	inch mm	11.5 291	5.3 133	7.9 201	1.97 50	1.38 35	21.6 548	18.8 478	3.67 93	3.25 83
EDx-20T	inch mm	13.7 348	6.0 152	9.0 229	2.75 70	2.0 51	29.7 754	25.2 640	5.7 146	5.0 127
EDx-50T	inch mm	15.8 400	6.08 172	10.3 262	3.88 99	2.75 70	40.5 1029	34.3 870	9.3 235	7.3 184
EDx-75T	inch mm	16.5 419	7.8 197	10.3 262	3.88 99	2.75 70	40.5 1030	34.3 870	8.9 225	7.3 184
EDx-100T	inch mm	18.0 457	7.8 197	11.0 280	5.00 127	3.25 83	47.7 1211	40.5 1027	11.2 284	7.8 200
EDx-150T	inch mm	21.0 533	8.8 222	12.6 321	5.25 133	3.75 95	53.9 1368	45.6 1159	12.3 313	9.0 229
EDx-250T	inch mm	27.0 686	9.8 248	17.5 445	8.5 216	5.00 127	75.8 1925	62.8 1595	17.9 454	13.0 330

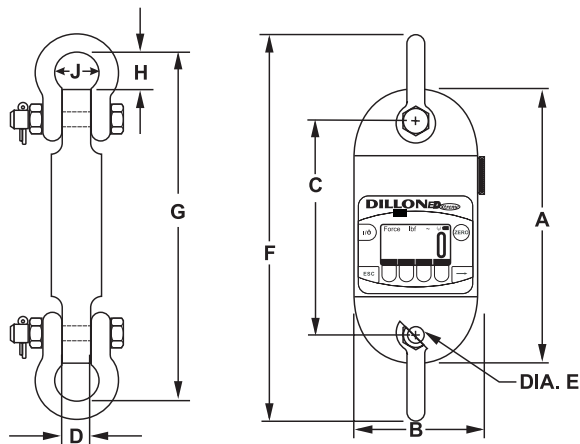

EDxtreme Electronic Dynamometer Specifications

Dynamometer Specifications

- Enclosure:** Designed to NEMA4X/IP55.
Suitable for continuous outdoor use.
- Accuracy:** 0.1% of capacity up to EDx-50T.*
0.3% of capacity for EDx-75T and above.*
- Repeatability:** 0.1% of capacity up to EDx-50T.*
0.3% of capacity for EDx-75T and above.*
* Normal resolution mode with Dillon provided shackles.
- Proof load:** 150% of capacity up to EDx-75T. 110% of capacity Edx-100T and above.
- Ultimate overload:** See table on reverse.
- Safe overload:** 200% of capacity
- Body protection:** Aluminum capacities are anodized. Alloy steel capacities are electroless-nickel plated.
- Bearings:** Unmatched repeatability attained by needle bearings in shackle pin holes up to EDx-5T. Shackle pin acts as inner race.
- Shackles:** Forged industry standard anchor shackles. Models up to EDx-5T use precision machined shackle pin. Higher capacities use bar stock pin.
- Display:** 128 x 64 dot-graphic LCD display shows up to 6 digits 1.0" (26 mm) high plus annunciators and softkeys. Digits are .11 inches (3 mm) thick for unmatched readability.
- Display update rate:** 2 times per second.
- Connector:** Recessed sealed connector may be used for serial communications or connection to a Communicator remote.
- RS-232 / RS-485 communication:** Print or extract data easily.
Continuous output can drive a scoreboard. Configurable poll character.
- Calibration:** Traceable to the National Institute of Standards and Technology. Certificate included with curve of readings. Passes only with three consecutive confirming runs, with all points in specification.
- Battery life:** 320 hours typical use with two C-cell alkaline batteries. 40 hours typical with Radio Link system.
- Operating temperature:** -4° F to 140° F (-20° to 60° C)
- Included with instrument:** All include certificate of calibration, manual and batteries. Plastic carry case included for EDx-1T to EDx-50T. Higher capacities include rugged plywood storage crate. Instruments with shackles include centering spacers (EDx-20T & up) and shackle storage crate (EDx-20T to EDx-75T).
- Options:** Shackles. Radio communications. Display backlight.

Communicator Specifications

- Enclosure:** Designed to NEMA 3 / IP44 with optional sleeve. Suitable for protected outdoor use.
- Instrument size:** 9.0 x 4.6 x 1.8 inch (228 x 117 x 45mm).
- Accuracy:** Not applicable. Only sends and receives digital information.
- Display:** 128 x 64 dot-graphic LCD display can show full readings up to 5 instruments.
- Battery life:** 40 hours radio or 45 wireline using four AA alkaline batteries under typical use.
- Operating temperature:** -4° F to 140° F (-20° to 60° C)
- Connectors:** Sealed connectors may be used for serial communications and wired connection to an EDxtreme dynamometer.
- RS-232 communication:** Print or extract data easily. Continuous output can drive a scoreboard. Configurable poll character.
- Included with remote:** Carry case and batteries.
- Accessories:** Rubberized case protector sleeve.
Remote wall mount bracket. Serial and remote cable assemblies.

Radio Specifications

- FCC Certified:** For unlicensed low power devices. No radio licensing or permits required for normal operation.* (In the US and Canada. Check local ordinances in other countries.)
- Frequency:** 2.4 GHz spread-spectrum operates between 2.402 – 2.478 GHz. Continuously and automatically changes frequencies many times per second for consistent, reliable communications.
- Output level:** 10 mW (20 dBm)
- Display update rate:** 2 times per second with single dynamometer.
Multi-instrument networks result in reduced updates.
- Number of networks:** 63 remotes can operate independently in the same airspace with unique channels.
- Number of links remote can control:** Up to 15 addresses are available per network channel.
- Configuration:** Address and network channels are front-panel configurable.
- Antenna:** Integral antenna.
- Range:** Open-air – Up to 300 feet, line-of-sight.
Indoors – Dependent upon environment with 150 feet common.
- Approval:** FCC ID: KQL-PKLR2400
CAN ID: CAN2268391158A
CE: EMC 89/336 Machinery Safety 98/37
- Low power radio systems are dependent upon interference levels from other radio systems and environmental conditions. Radio devices are not suitable for all applications.

WEIGHTS

Model	Unit Weight	Weight with Shackles	Approx. Shipping Weight
EDx-1T	lb	4.3	13
	kg	2.0	6
EDx-2T	lb	4.4	13
	kg	2.0	6
EDx-5T	lb	5.6	22
	kg	2.5	10
EDx-10T	lb	16	46
	kg	7.3	21
EDx-20T	lb	25	125
	kg	11	56
EDx-50T	lb	38	296
	kg	17	134
EDx-75T	lb	54	325
	kg	25	145
EDx-100T	lb	70	480
	kg	32	218
EDx-150T	lb	120	750
	kg	54	340
EDx-250T	lb	250	1,600
	kg	113	725
Communicator	lb	1	10
	kg	.5	5

AUTHORIZED DISTRIBUTORS

Ask the experts. Dillon distributors offer complete service capabilities from application assistance to sales and product support. Their experienced representatives are the most knowledgeable experts that you will find in the force measurement industry. We recommend that you consult these capable specialists for all of your measuring needs.

Please call us or visit
www.dillon-force.com
for your nearest
Dillon distributor.

DILLON

Force Measurement Equipment
a division of Avery Weigh-Tronix, LLC
Fairmont, MN U.S.A.
Toll-Free: 800-368-2031
Phone: 507-238-8796
Fax: 507-238-8258
www.dillon-force.com

